

ECONOMIC COMMUNITY OF WEST
AFRICAN STATES



COMMUNAUTE ECONOMIQUE DES
ÉTATS DE L'AFRIQUE DE L'OUEST

ECW/CMILXVI/20IREV.2
Original: English

**SIXTY-SIXTH ORDINARY SESSION
OF THE ECOWAS COUNCIL OF MINISTERS**

Abuja, 17th - 19th August 2011

FINAL REPORT

Abuja, August 2011

I. INTRODUCTION

1. . The Sixty-Sixth Ordinary Session of the ECOWAS Council of Ministers was held at the ECOWAS Commission, Abuja on 17th – 19th August 2011.

2. The following Member States were represented:

- Republic of BENIN
- BURKINA FASO
- Republic of CAPE VERDE
- Republic of COTE D'IVOIRE
- Republic of The GAMBIA
- Republic of GHANA
- Republic of GUINEA
- Republic of GUINEA-BISSAU
- Republic LIBERIA
- Republic of MALI
- Republic of NIGER
- Federal Republic of NIGERIA
- Republic of SENEGAL
- Republic of SIERRA LEONE
- TOGOLESE Republic

3. The following institutions and specialized agencies of ECOWAS were also represented:

- ECOWAS Parliament;
- Community Court of Justice;
- West African Health Organisation (WAHO);
- Inter-Governmental Action Group Against Money Laundering in West Africa (GIABA);
- ECOWAS Gender Development Centre;
- West African Power Pool (WAPP);
- ECOWAS Regional Centre for Renewable Energy and Energy Efficiency (ECREEE);
- ECOWAS Regional Authority for Renewable Energy (ERERA).

4. The list of participants is attached as an Annex to this report.

11. OPENING SESSION

- Address by the President of the ECOWAS Commission

5. In his welcome address, the President of the Commission, H.E. **James** Victor Gbeho, specially welcomed H.E. Ambassador O1 **ugbenga**

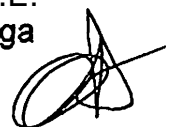

Ayodele Ashiru, MFR, the Hon Minister of Foreign Affairs of the Federal Republic of Nigeria and current Chairman of the Council of ministers who was attending his first meeting of the Council and congratulated him on his appointment. He also commended Members of the Council for their demonstrated commitment to the Community's objectives through their regular attendance and active participation in the deliberations of Council, despite their very busy schedules.

6. He noted that the current Session of the Council was being held against the backdrop of several political and security developments in the ECOWAS region such as the resolution of the crisis in Côte d'Ivoire, the restoration of constitutional order and legality in Guinea and Niger, the successful holding of Parliamentary elections in Cape Verde, the Presidential elections in Benin and the Parliamentary and Presidential elections in the Federal Republic of Nigeria. In all of these instances, he said, ECOWAS played and continued to play its role in ensuring that the region was on course in its drive to consolidate democracy and create the right conditions for greater regional integration.

7. He concluded by stating that the vast experience of the members of the Council and their commitment to ECOWAS and the regional integration process, would be needed in confronting the tasks before them.

Address by the Chairman of the Council of Ministers

8. In his opening address, the Chairman of the Council, H.E Ambassador Olugbenga Ayodele Ashiru (MFR), welcomed members of the Council to the session and particularly thanked his Muslim colleagues for enduring the physical and spiritual demands of fasting during the holy month of Ramadan in order to attend the meeting.

9. He acknowledged the significant progress recorded by the region within the last year in the consolidation of peace, political stability and democratic governance, with the successful conduct of elections in Benin, Guinea and Nigeria, and the restoration of democratic governance in Niger and Côte d'Ivoire. He expressed confidence that the region will continue along this path of full democratic governance by ensuring the sustainability of democracy, peace and political stability, which are the necessary prerequisites for economic development.

10. He however, observed with regret that in the area of economic integration, there were still gaps in the implementation of the ECOWAS Protocol on Free Movement of Persons, Goods and Services and the Right of Residence and Establishment. Describing the instrument as a **key**



element in the regional integration project, he noted that this Protocol remained to be fully implemented after thirty-two years. He pointed out that the success of ECOWAS Agricultural, Trade and Economic Development programmes was very much dependent on the full implementation of the Protocol.

11. The Minister also drew attention to the apparent financial indiscipline in the Community Institutions occasioned by the continuous non-implementation of the 60:40 ratio stipulated by the ECOWAS Authority of Heads of State and Government for budgetary expenditure for programmes vis-a-vis administrative costs. As a result, he observed, ECOWAS development partners are losing confidence to support ECOWAS integration efforts.

12. He concluded by reiterating the commitment of H.E. Dr. Goodluck Ebele Jonathan GCFR, President of the Federal Republic of Nigeria and current Chairman of the Authority, to the sustenance of the ECOWAS organization and the principles of the rule of law and democratic governance in the sub-region.

13. The full texts of the speeches are annexed to this report.

III. ELECTION OF BUREAU

14. The following Bureau was elected:

- Chairman Nigeria
- Rapporteurs- Ghana
 Niger

IV. ADOPTION OF AGENDA AND WORK PROGRAMME

15. At the request of the Chairman, the meeting observed a minute's silence in honour of Alhaji Mohamed Bashir Daramy, the late ECOWAS Commissioner for Trade, Customs Industry, Mines and Free Movement, who passed away on 12th July 2011.

16. The following agenda was adopted for the 66th Ordinary Session of Council

1. Opening Ceremony:

- Opening Statement by the Host Minister, Chairman of **Council**
- Statement by the President of the ECOWAS Commission



2. Election of Bureau
Adoption of the Draft Agenda and Work Programme

Items for Decision

3. Presentation and Consideration of the 2011 Interim Report of the President of the ECOWAS Commission (Summary Report)
4. Status of Tasks Assigned from the 65th Ordinary Session of the ECOWAS Council of Ministers
5. Presentation and Consideration of the Financial Controller's 2010 Annual Report
6. Presentation and Consideration of the Reports on the Audit of Recruitment. Memo on the Staff Needs of the Commission and Lifting of the Recruitment Freeze
7. Presentation and Consideration of the Reports of the 18th, 19th and 20th Meeting of the Audit Committee
8. Presentation and Consideration of the Report of the Ninth Meeting of the Administration and Finance Committee
9. Presentation and Consideration of the Report of the Ad hoc Ministerial Committee on Construction of Headquarters of Community Institutions
10. Presentation and consideration of a report from Burkina Faso on Free Movement of Persons, Goods, Right of Residence and Establishment in the ECOWAS Region

Items for Endorsement

11. Presentation of the Report of the Meeting of the Ministerial Committee on Agriculture, Environment and Water Resources to review the 2010 achievements and the 2011 prospects under the ECOWAS/CMDP process held in Accra (Ghana), 3rd February, 2011.
12. Presentation of the Report of the Meeting of Ministers Responsible for Livestock to validate the Strategic Action Plan for the Development and Transformation of Livestock **Farming**



in ECOWAS Member States held in Bamako (Mali), 10th March 2011.

13. Presentation of the Report of the Meeting of the Ministers of Transport, Infrastructure and Energy on the Draft Regulation of the Projects Preparation Development Unit (PPDU) and the Harmonization of Axle Load Control Policy in the ECOWAS Member States held in Accra (Ghana), 1st April, 2011
14. Presentation of the Report of the Meeting of Ministers of Justice of ECOWAS Member States, held in Abuja. 16th-17th May, 2011
15. Presentation of the Report of the 3rd Meeting of ECOWAS Ministers in charge of Mineral Resources, held in Accra (Ghana), 3rd June, 2011
16. Presentation of the Report of the Ministers in charge of Security Questions in Member States held in Abuja (Nigeria). 6th November. 2009
17. Presentation on the launch of the ECOMAC Database
18. Presentation and Consideration of the Memorandum Relating to the Request by Member States for ECOWAS Endorsement of Candidates to Vacant Positions in International Organisations
19. Any Other Business
 - Consideration of the Draft Agenda of the Next Summit of the Heads of State and Government
20. Adoption of Report
21. Closing Session

V. OUTCOME OF DELIBERATIONS

Item 3: Presentation and Consideration of the 2011 Interim Report of the President of the ECOWAS Commission (Summary Report)

17. The President of the ECOWAS Commission, His Excellency James **Victor** GBEHO presented the 2011 Interim Report. In his **presentation, he**

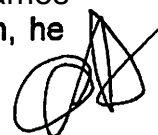

made a summary of the global and regional development prospects for 2011 as well as the status of implementation of the Community's work programme.

18.. The presentation highlighted that, according to the latest IMF estimates. the global economy will grow by 4.5% in 2011 and that economic growth in the West Africa region will reach 6.4% in 2011 **compared** to 5% in 2010.as a result of the global economic recovery. This rate is still below the minimum 7% target rate for the region to achieve the MDGs and Member States are therefore urged to improve their internal resource mobilization strategies, increase investments in the social sectors and ensure appropriate management of current expenditures.

19. Concerning implementation of the Community's 2011 work programme, the President presented the progress achieved in all programmes relating to all sectors. He observed that significant progress has been achieved during the first Semester and stated that efforts will be continued to ensure adequate implementation of the projects identified under the 2011 work programme.

20. Accordingly, with regard to Macroeconomic Policy, the presentation highlighted the continued coordination of the economic and financial policies. implementation of the roadmap actions relating to the ECOWAS single currency as well as surveillance of the economic performance of the countries through the multilateral surveillance mechanism. Implementation of the regional poverty reduction strategy also continued during the Semester and measures were taken to ensure its ownership by Member States and all stakeholders concerned.

21. Concerning the EPA, the President reported that the negotiations at the level of the experts should continue with a view to ensuring that the region's development objectives are taken into account, while in the area of Trade Liberalization, it should be noted, among others, that a website was created for the Trade Liberalization Scheme (TLS) to facilitate the flow and exchange of related information. However, obstacles were observed in implementation of the TLS and appeal was made to the concerned Member States to ensure its effective implementation. As for the ECOWAS CET, consultations are continuing for its finalization and adoption.

22. In the area of Industries and Mines, the President reported that ECOWAS has validated the priority programmes of the West African Common Industrial Policy as well as the ECOWAS Mineral Resource Development Policy, while in connection with Free Movement, the

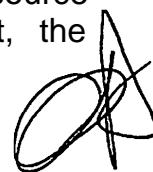

President reported that sensitization and training activities have been undertaken for the stakeholders.

23. Regarding the area of Infrastructure, actions have been undertaken especially in terms of transport and transit facilitation and implementation of telecommunications and energy infrastructure. The ECOWAS Commission continued providing support to Guinea within the framework of the emergency plan for the resolution of its energy challenges in conformity with the decision of the Authority of Heads of State and Government.

24. Under Agriculture, ECOWAS finalized the regional agricultural investment plan and the policy instruments and provided support to the countries for the elaboration of their national agricultural investment plans. The resource mobilization process for the implementation of all the plans is ongoing.

25. Concerning Humanitarian Affairs, the ECOWAS Commission prepared the draft Humanitarian Policy, Action Plan and draft Humanitarian Intervention Mechanism. The Commission provided assistance to Community citizens during emergency situations in Jos, Nigeria, Cote d'Ivoire and Libya. Efforts have also been made in the fight against drug trafficking and in the promotion of cultural and sports activities.

26. In the area of Peace and Security, there has been tangible progress in the region with the successful conduct of elections during the first quarter of 2011. ECOWAS was actively involved as part of efforts to implement the Protocol on Good Governance. In that context, the Institution participated, alongside the International Community in Cote d'Ivoire, in the restoration of democratic governance and provided support to Member States in the conduct of democratic elections. It strongly condemned the events that occurred in Guinea and Niger, as well as the terrorist attacks in Nigeria, and expressed concern over the effects of the current crisis in Libya on ECOWAS Member States.

27. After announcing the outlook for 2011, the Commission President urged all political leaders to continue supporting ECOWAS programmes, with a view to establishing a regional economic area that is credible, viable and conducive to regional integration.

28. Council commended the President of the Commission on the quality of his report. It however requested the Commission to review the format of the report with a view to bringing to the fore the progress accomplished in relation to the objectives assigned by the Commission. Council subsequently adopted the report.



Item 4: Status of Tasks Assigned from the 65th Ordinary Session of the ECOWAS Council of Ministers

29. After presentation by the Commission on the four tasks given to the Commission from the 55th Council of Ministers, it was found that while some tasks were addressed, others were still outstanding in particular the task of convening an Ad Hoc Ministerial Committee of Council to study the recommendations on causes of low budget absorption.

30. Council decided that all the tasks should be completed together and represented at the next Council of Ministers meeting.

Item 5: Presentation and Consideration of the Financial Controller's 2010 Annual Report

31. Council noted the lack of consensus on the appointment of an acting Financial Controller and on who should present the 2010 Final Report of the Financial Controller.

32. Furthermore Council decided that, in consultation with the President of the Commission, the Chairman should appoint an interim Financial Controller from amongst the officials of that office to act in that position until the end of the year. It is understood that, at the end of that period, the Financial Controller would present a report prior to the appointment of a substantive Financial Controller.

Item 6: Presentation and Consideration of the Reports on the Audit of Recruitment. Memo on the Staff Needs of the Commission and Lifting of the Recruitment Freeze

33. The ECOWAS Commission presented the Report of the two audits on Recruitment and the Memorandum on Staff Needs and the lifting of the freeze on recruitment.

34. In their presentation, the Commission recalled the first phase of recruitment in the ECOWAS Commission in 2007/2008 which began with the recruitment of Directors and PS Managerial Officers. The Commission also recalled the subsequent decision of the 61st Council of Ministers to conduct an audit of the recruitment process in order to evaluate its effectiveness, and to freeze the recruitment of staff into permanent positions pending the outcome of the audit exercise.



35. The Commission then went on to highlight the efforts made towards the implementation of the recommendations of the Audit Reports on recruitment as follows:

- The Development of a Recruitment Manual
- The Conduct of a Job Evaluation Exercise
- The setting up of an E-Recruitment portal
- Equitable geographical distribution and gender balance

36. The Commission also highlighted the effects of the freeze on recruitment and highlighted the reasons for lifting such freeze as follows:

- The problem of low budget absorption capacity as well as the low rate of programme implementation of the ECOWAS Commission, due to staff shortages in several Departments.
- The top-heavy manning/staffing structure of the Commission with some Directorates having only a Director and one PS Managerial Staff, and no programme staff below that level.
- The repeated observations in the Financial Controller's reports, the Budget Sessions of the Administration and Finance Committee (AFC) meetings of October 2009 and 2010 which were replete with complaints from Commissioners, particularly those of the technical departments on the problem of inadequate staffing as one explanation for low programme execution;
- The ECOWAS/Donor Partners Conference held in June 2011, where the partners severally expressed concern over the long-drawn effect of the freeze on recruitment and its negative impact on ECOWAS Programmes which had led to the following:
 - Low budget absorption;
 - Low programme implementation;
 - Loss of credibility of **ECOWAS** Institutions;
 - Inadequate absorption of external funds;
 - Unease the donor partners, particularly the European Union, who had written to the President of the Commission and to the Chairman of the Authority, expressing grave concern about the recruitment freeze and expressing the possibility of suspending their support to ECOWAS.
 - The Pool Fund Partners who have already suspended any new additional funding.



37. In their conclusion and prayer, the Commission invited the 66th **Session** of Council to consider the issues highlighted above and approve the lifting of the freeze on staff recruitment, to enable the recruitment of staff critical to the implementation of programmes. This would not only enhance programme and budget absorption but also address the concerns of the Commission's donor partners.

38. Council took note of the reports presented by the Commission. After the presentation, Council decided that it was rather time to review and reposition the ECOWAS Institutions, after the first tenure of the Commission, in terms of financial management, recruitment, discipline, engagement of consultants and other important procedures. This is to assess the institution's strength and stem the tide of concerns from Member States, staff and other stakeholders in the ECOWAS enterprise.

39. Council mandated the Chairman, in consultation with the President of the Commission, to contract an independent reputable firm of management consultants, preferably from outside Africa to give urgent effect to this decision to reposition our Community institutions in line with international best practices. This is to be done before the end of 2011. Council decided to maintain the freeze on recruitment until the independent Audit firm presents its conclusions and recommendations.

Item 7: Presentation and Consideration of the Reports of the 18th, 19th and 20th Meeting of the Audit Committee

40. The Chairman of the Audit Committee presented the reports of its 18th, 19th and 20th meetings. Council took note of the report and the recommendations contained therein and noted that the recommendations further justified the engagement of a management consultancy firm for the review of the administrative, human resources, consultancy, financial management and other policies of the Community as decided under Item 6 above. Only the 2010 concluded financial statements from the report were adopted.

Item 8: Presentation and Consideration of the Report of the Ninth Meeting of the Administration and Finance Committee

41. The final report of the 9th meeting of the Administration and Finance Committee was presented by the Chairman of the Committee, Ambassador A.A. Abass. The report dealt mainly with the following issues:

- Implementation status of tasks assigned;



- Supplementary BUDget to deal with the Humanitarian situation in Cote d'Ivoire, Liberia, Guinea. Ghana and Mali;
- GIABA Strategic Plan 2011-2014 and GIABA Organogram;
- Sitting allowance for GIABA's Ministerial Committee members;
- Creation of the position of Director in the office of the Financial Controller;
- Establishment of ECOWAS Common Investment Market Councils at Regional and National levels;
- Modalities for the establishment of the ECOWAS Pension Scheme;
- 2010 Final Report of the Financial Controller;
- Briefing on Administrative issues;
- Report of the first ECOWAS SME Summit; and
- Report of the first ECOWAS Diaspora Forum.

42. Council adopted the report and the recommendations contained therein.

Item 9: Presentation and Consideration of the Report of the Ad hoc Ministerial Committee on Construction of Headquarters of Community Institutions

43. The report was presented by H. E. Ambassador Abbas, Chairman of the meeting and centred on the following projects:

- ECOWAS Logistics depot located at Lungi in Sierra Leone;
- Construction of the headquarters of the ECOWAS Stand-by Force;
- Katampe Staff Housing Estate- status report

44. After due deliberations, Council directed the Commission to ensure that the extant Community regulations for contract awards should be adhered to in all future contracting of jobs on this nature.

45. Council thereafter adopted the report and decided as follows:

- The appointment of the consultant for the development of the ECOWAS Logistics Depot was ratified as an exceptional case, considering the huge sums of money already committed by the Government of Sierra Leone and the Commission and the time lost in order to move the project forward. However, all subsequent steps must comply with due process while the present ratification should not be cited as precedent in the future.
- On the Katampe Staff Housing Estate, Council endorsed the recommendation of the Ad-Hoc Ministerial Committee which is to

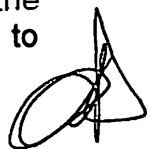

await the outcome of the discussion between ECOWAS and the Federal Government of Nigeria.

Item 10: Presentation of a Report from Burkina Faso on Free Movement of Persons, Goods, Right of Residence and Establishment in ECOWAS Area

46. The Burkina Faso delegation reported that the Protocol on Free Movement adopted in 1979 by the Community was a wise decision by our Heads of State for it had helped bring people together. The ECOWAS Passport, Vaccination Card and visa waiver for ECOWAS nationals are important instruments that have been of great service to West African citizens.

47. However, some difficulties continue to be encountered in the actual implementation of the Protocol on Free Movement. Burkina Faso took the initiative to establish - by ministerial decree - a national Committee on the Free Movement of Persons and Goods, Right of Residence and Establishment, and to adopt a national monitoring strategy.

48. Burkina Faso is also taking out measures to roll out the ECOWAS passport, and hopes this initiative would be extended to all Community countries, a monitoring mechanism set up, the necessary funds provided, and a Head of State appointed to lead the initiative in the entire community.

49. Following extensive discussions, council noted the report and observed that similar initiatives already exist in many member states.

ITEMS FOR ENDORSEMENT

Item 11: Presentation of the Report of the Meeting of the Ministerial Committee on Agriculture, Environment and Water Resources to review the 2010 achievements and the 2011 prospects under the ECOWAS/CAADP process held in Accra (Ghana), 3rd February, 2011

50. The report of the Meeting focused on the review of the 2010 achievements of the ECOWAS/CAADP process and adoption on the 2011 work plan and priorities. The meeting noted that the 2010 achievements are as follows:

- National Agriculture and Investment plan and pacts formulated and adopted in all Member States;



- **Detailed** national plans for twelve Member States ready for external review;
- Initial funding had been mobilized by most countries under their respective GAFSP and GFRP;
- Finalization of the Regional Investment Programme; Public policy instruments had been designed;
- The design of institutional and financial framework had been produced; and
- Monitoring and evaluation mechanism had been designed.

51. The following priorities and work plan was adopted for 2011:

- Strengthening the ECOWAS/CAADP Steering Mechanism including the technical and financial partners coordination mechanism;
- Establishment of financial and institutional mechanism for the Regional and Agricultural Fund and its effective take-off;
- Implementation of the Regional Agricultural Investment Programme;
- Intensification of Community support toward the implementation of National Agricultural Investment Plans in Member States;
- Regional monitoring and evaluation mechanism being made functional; and
- Launching of an effective communication programme to ensure visibility of ECOWAP.

52. Council adopted the report.

Item 12: Presentation of the Report of the Meeting of Ministers responsible for Livestock to validate the strategic Action Plan for the Development and Transformation of Livestock Farming in ECOWAS Member States. held in Bamako (Mali), 10th March. 2011

53. The meeting, which was held on 10th March, 2011 at Bamako in Mali on the ECOWAS Commission's initiative, was aimed, on one hand, at validating the Strategic Action Plan for the economic transformation and development of the sectors of cattle, meat and dairy, with a view to a sustainable food security, poverty reduction and procurement of income for the stakeholders while preserving their natural resources; and on the other hand, approving Mali's request for making the Regional Animal Health Centre, a specialized ECOWAS Centre for Animal Health.

54. The Council of Ministers Responsible for Stock Farming adopted the technical report, amended and approved the strategic action plan for the development and transformation of stock farming in West Africa, as well as

the establishment of the Regional Animal Health Centre (RAHC) as a specialized Centre for ECOWAS. The amendments take due account of the problems of Water, Natural Resources, Transhumance and Gender. Recommendations were made for the expeditious implementation by the Commission of the Action Plan and application of the commitments and recommendations made by the Member States to allocate the necessary resources to the sector.

55. Considering the relevance of the Strategic Plan proposed and its consonance with national and regional priorities, the Member States were called upon to take up their responsibilities.

56. Finally, the Council of Statutory Ministers adopted the plan and recommendations made and the establishment of the RAHC as a specialized centre of the Community.

Item 13: Presentation of the Report of the Meeting of the Ministers of Transport, Infrastructure and Energy on the Draft Regulation of the Projects Preparation Development Unit (PPDU) and the Harmonization of Axle Load Control Policy in the ECOWAS Member States held in Accra (Ghana). 1st April 2011

57. The Minister of Roads and Highways of Ghana, Honourable Mr. Joe Gidisu, presented the Report of the Meeting of the ECOWAS Ministers of Transport, Infrastructure and Energy on the Draft regulations of the Projects Preparation and Development Unit (PPDU) and the Harmonization of the Axle Load Control Policy in the ECOWAS Member States, held in Accra, Ghana on 1st April 2011.

58. In his presentation, he highlighted the Decisions taken at the meeting in respect of the following:

- The Draft ECOWAS Harmonized Regulation on Axle Load Control;
- The ECOWAS Road Map for the implementation of Axle Load Regulation;
- PPDU Regulation.

59. In conclusion, the Minister informed the Council of the recommendations made by the Ministerial Committee and requested the adoption of the following:

- The Draft Supplementary Act relating to the harmonization of standard procedures for control of the gauge, the weight and the axle load and its road map;

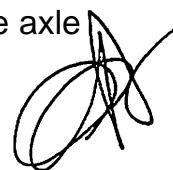

- The **Draft Regulation** relating to the denomination and the **establishment of the rules** for the functions, organization and mode of **operations** of the ECOWAS Projects Preparation and Development Unit;

60. The Council adopted the report and the recommendations.

Item 14: Presentation of the Report of the Meeting of Ministers of Justice of ECOWAS Member States, held in Abuja. 16th.17th May, 2011

61. The report of the meeting of ECOWAS Ministers of Justice was presented by the Attorney General and Minister of Justice of the Federal Republic of Nigeria, Alhaji Mohamed Bello Adoke, SAN who chaired the meeting.

62. In his presentation, he recalled that the meeting considered the draft Supplementary Act relating to Sanctions to be imposed on Member States that default in their obligations to ECOWAS, including the modalities for its imposition; and the draft Directive for Fighting Cyber Crime in Member States.

63. He requested Council to adopt the report and recommend the draft Supplementary Act and the Directive for Fighting Cyber Crime for adoption by the Authority of Heads of State and Government.

64. Council adopted the report.

Item 15: Presentation of the Report of the 3rd Meeting of ECOWAS Ministers in charge of Mineral Resources, held in Accra (Ghana), 3rd June, 2011

65. The third meeting, which was held in Accra, Ghana on 3 June 2011, considered the following:

- Report of the 1st meeting of the Ad-hoc Committee on the monitoring of implementation of ECOWAS Directive *C/DIR3/5/09* on the mining sector, which was held in Dakar, Senegal from 25 to 26 May 2011;
- Report of the National Experts Workshop, which was held from 30 May to 1st June 2011. The workshop finalised the mineral resource development policy and action plan, and recommended the establishment of a working group to include Ghana, Senegal and Sierra Leone, to consider the alternative proposals on a Roadmap for the Regional Cadastre System; and

- **Draft Supplementary Act** on the ECOWAS mineral development policy to be submitted to the Authority of Heads of State and Government, in view of the adoption of the mineral development policy and action plan.

66. The policy seeks to harness mineral resource capital in the region, in such a way as to promote sustainable economic growth and integrated socio-economic development. It draws inspiration from ECOWAS Directive C/DIR.3/3/5/09, takes into account the major challenges of the mineral sector and includes a total of nine (9) strategic areas and programmes. These programmes cover the enhancement of geological and mineral information, improvement of mineral revenues management, policy on the integration of local components in mining operations, capacity building, improvement of the institutional, legal and regulatory frameworks; sustainable development and corporate social responsibility, infrastructural development; development of traditional and small-scale mining activities and strengthening of regional cooperation in the mining sector.

67. The Ministers undertook to facilitate the publication, in their respective National Gazettes, of the Directive on harmonisation of guidelines and policies on the mining sector. They approved the terms of reference for the ECOWAS Forum on Petroleum and Mines and the choice of a host country and consultant.

68. The Council of Ministers decided to submit the ECOWAS Mineral Development Policy to the ECOWAS Authority of Heads of State and Government for adoption.

Item 16: Presentation of the Report of the Ministers in charge of Security Questions in Member States held in Abuja (Nigeria), 6th November 2009

69. The Council of Ministers considered the following documents:

- the report of the constitutive assembly of the Committee of Security Service Chiefs at the end of the meeting of ECOWAS Member States' Police and Gendarmerie Chiefs, held in Dakar, Senegal on 19 and 20 May 2009, taking into account the formation of the Committee of Security Service Chiefs (CSSe), and the code of conduct of the armed forces and security services in West Africa.
- The final report of the 7th meeting of the Forum of Ministers in charge of Security Questions in ECOWAS Member States was held on 6 November 2009. It also considered the Committees of Security Chiefs for cross-border security, proliferation of small arms and **light**

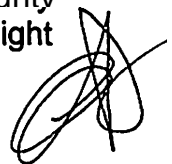

weapons, terrorism by supporting Interpol, capacity building, and services.

- The **report** of the **8th meeting** of the Forum of Ministers responsible for Security was held in Abuja on 30 July 2011. Specific provisions were considered.

70. **After** consideration, the Council of Ministers adopted the aforementioned reports, as well as the created specific bodies and code of conduct. The adoption confirms the retention of the Regional Interpol Bureau in Abidjan, support for the efforts of Interpol to the European Union for the creation of the West Africa Information System, implementation of the Protocol of the Office for information and criminal investigations, training and capacity building, synergy of action between GIABA and the Community Court of Justice and the use of new technologies. In this regard, the Division in charge of Regional Security at the ECOWAS Commission should be reinforced. The principles of the code of conduct reaffirm the sovereignty of national integrity, supremacy of civilian authority, respect for human rights and humanitarian law as well as civilian-military relations.

71. Furthermore following the submissions made by the President of the Commission and the Minister responsible for Police Affairs of the Federal Republic of Nigeria on matters relating to this issue as well as the concerns over the security situation in the region. Council decided to recommend to the next session of the ECOWAS Authority of Heads of State and Government the abolition of resident permits for all ECOWAS citizens in Member States and the adoption of multi-country single visa (Schengen type) for third-country nationals travelling within Member States of the region. Council also recommended that serious attention be paid to cross-border security, proliferation of small arms light weapons and terrorism by supporting the Interpol capacity building and services.

Item 17: Presentation on the launch of the ECOMAC Database

72. In its presentation to the Council of Ministers on the launch of the ECOMAC Database, the Commission indicated that the ECOMAC Database is the tool for implementing the ECOWAS multilateral surveillance mechanism. It is also in line with the objectives of the Authority of Heads of State and Government on the implementation of macro-economic convergence within the context of the ECOWAS monetary cooperation programme.



73. It also pointed out **that** the ECOMAC database is aimed at ensuring the accuracy and comparability of macro-economic data for the attainment of the convergence of economies at national level towards the launch of a credible Monetary Union in our region.

74. The Council of Ministers adopted the communication made after the presentation.

Item 18: Presentation and Consideration of the Memorandum Relating to the request by Member States for ECOWAS Endorsement of Candidates to Vacant Positions in International Organisations

75. The President of the Commission informed the Council that some Member States had submitted their candidates for positions in the African Union Commission and in the United Nations.

76. He indicated that for most positions one candidacy had been recorded, except those of the positions of the African Union Commissioner for Political Affairs and Commissioner for Social Affairs. For each of these two posts, two candidacies were recorded from more than one Member State.

77. The Chairman said that as a practice, the two countries with candidates for the same position should meet informally and negotiate in order to agree on which single country should be put forward and thereafter communicate their agreement as a matter of urgency to the President of the ECOWAS Commission. However, Council decided to give support for candidacies for positions which has recorded only one nomination.

78. The Chairman then drew members' attention to the rules of procedure for submission of candidacies.

79. In response to a concern expressed by Liberia over the publication of the AU positions, the Chairman indicated that it was not ECOWAS' responsibility to put up adverts for the AU but all requests for nomination were found on the AU website.

A handwritten signature in black ink, consisting of several overlapping loops and a long horizontal stroke extending to the right.

Item 19: Any other business

- Consideration of the Draft Agenda of the Fortieth Ordinary Summit of Head of State and Government

80. Council considered and adopted the Draft Agenda of the Fortieth Ordinary Summit of Heads of State and Government as presented by the Commission.

- Progress Report on the Fight Against Malaria in the Region

81. The President of the Commission updated Council on the progress registered so far in the fight against malaria in the sub-region and reminded them of the MDGs which provide for the reduction of Malaria by 75% by 2015. He promised to bring all management teams in the Member States to redouble their efforts in the eradication of Malaria;

- Progress Report on the donation of Equipment for the ECOWAS Logistic Depot in Freetown, Sierra Leone by the Government of United States of America

82. The President of the Commission also updated Council on the donation of Equipment at the Murraytown Logistic facility in Sierra Leone for the take off of the ECOWAS Logistic Depot. He stated that the conditions set by the Government of the United States of America on the donation of the Equipment at the facility to ECOWAS were not acceptable. The conditions gave ownership of all equipment during and after the transition to the Government of the United States of America. Negotiations were underway to reach a compromise on the issue

- Recruitment of a Management Consultant to review ECOWAS Organisational and Management Procedures With Support of the Audit Committee and the Commission

83. A Member State proposed that the Chairman of Council should take up leadership and coordination of the work of the Management Consultant that would be engaged as decided by Council in paragraphs 39 and 40. It also proposed that the Audit Committee be given the mandate to draft the Terms of Reference for the Management Consultant. The Council accepted that the Audit Committee should assist the management consultants' work under the administrative support of the Commission.



- Return of the Headquarters of African Development Bank to Abidjan, Côte d'Ivoire

84. The Republic of Cote d'Ivoire requested for and received the support of Council on their efforts to return the headquarters of the African Development Bank to Abidjan, COte d'Ivoire for the recovery of the economy.

- Emergence of Piracy Activities in Coastal Waters of the Region

85. The Republic of Benin expressed grave concern about the emergence of piracy in the Coastal Waters of the Region notably in the territorial waters of the Republic of Benin and urged Council to take up the matter as an ECOWAS problem and bring it up to the attention of the Heads of State.

86. Council took note of Benin's concerns and requested the ECOWAS Commission to urgently convene a meeting of the ECOWAS Chiefs of Defence Staff to address the matter.

- Payment of Community Levy

87. The Chairman called on Member States who have not paid up their Community Levy to do so and in order to aid the integration efforts of the Community Institutions

- Proposal for increase of the Number of ECOWAS Commissioners to Fifteen

88. In response to the recommendation from a Member State that the number of Commissioners should be increased from the present nine (9) to fifteen (15), the Chairman informed Council that all the issues related to the matter was already before the Authority and will be considered at the next session of the body.

- Granting of Diplomatic and Consular Status to ECOWAS by the Government of United States of America

89. The Chairman informed Council that he has personally written a letter to the Government of United States of America requesting that ECOWAS be granted diplomatic and consular status and all privileges that go along with it by the authorities of that country. He also enjoined members of Council to take up the **matter** on bilateral level when they visit or **receive** officials of Government of United States of America.

Item 20: Adoption of the Report

90. This report was adopted after amendments.

Item 21: Closing Session

91. In his closing remarks, the Chairman of Council congratulated his colleagues on the quality of work done and the spirit of comradeship and cooperation that prevailed throughout their deliberations, which enabled them to conclude their deliberations *within* the appointed time. He concluded by wishing all participants safe journey back to their respective destinations.

DONE AT ABUJA THIS 19th DAY OF AUGUST 2011

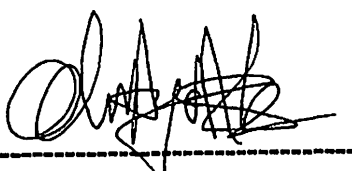

H.E. OLUGBENGA AYINDE ASHIRU, MFR
HONOURABLE MINISTER OF FOREIGN AFFAIRS
FEDERAL REPUBLIC OF NIGERIA
CHAIRMAN
FOR THE COUNCIL OF MINISTERS

COMISSÃO DA CEDEAO

EC-OWAS COMMISSION



COMMISSION DE LA CEDEAO

VOTE OF THANKS

The participants at the Sixty-Sixth Ordinary Session of the ECOWAS Council of Ministers held in Abuja, from 17th to 19th August 2011, express their profound gratitude to His Excellency, Goodluck Ebele Jonathan, President of the Federal Republic of Nigeria and Chairman of the Authority, and to the Government and people of Nigeria for the warm African hospitality extended to them during their stay in Abuja and for the facilities placed at their disposal to ensure the success of their meeting.

DONE AT ABUJA THIS 19th DAY OF AUGUST 2011

THE MEETING



SIXTY-SIXTH ORDINARY SESSION
OF THE COUNCIL OF MINISTERS

Abuja, 17 - 19 August 2011

REGULATION C/REG.1/08/11 ESTABLISHING
THE REGIONAL FOOD AND AGRICULTURE AGENCY (RFAA)

THE COUNCIL OF MINISTERS,

MINDFUL of Articles 10, 11 and 12 of the ECOWAS Treaty as amended, establishing the Council of Ministers and defining its composition and functions;

MINDFUL of Article 25 of the said ECOWAS Treaty on Agricultural Development and Food Security;

MINDFUL of Decision AIDEC.11/01/05 adopting the ECOWAS Agricultural Policy;

C.O NSIDERING the need to establish operational structures with autonomous administrative and financial management to ensure implementation of the ECOWAP/CAADP projects and programmes;

C ONSIDERING that the purpose of establishing these structures is not to replace existing technical cooperation institutions or to preclude the establishment of such institutions in the future;

C ONSIDERING the need to put in place technical institutions that have the capacity to implement activities and investment programmes within the Agricultural sector;

C ONSIDERING therefore that the Agency shall serve as the technical institution through which ECOWAS would fully play its role of providing

support to the actors and regional cooperation institutions to implement the investment programmes;

CONVINCED that, by virtue of the purpose of the ECOWAP/CAADP which is to promote food security, in West Africa, there is a need to establish the Regional Food and Agriculture Agency to ensure the technical implementation of the required regional investment plans and programmes with the support of the regional institutions, organisations and actors that have proven competencies;

DESIROUS therefore of establishing a Regional Food and Agriculture Agency (RFAA);

ON THE RECOMMENDATION of the meeting of the Specialised Ministerial Committee on Agriculture, Environment and Water Resources of the ECOWAS Member States held on 3rd February 2011 in Accra, Ghana;

AGREE AS FOLLOWS:

ARTICLE 1 ESTABLISHMENT

This Regulation hereby establishes the Regional Food and Agriculture Agency (RFAA).

ARTICLE 2 INSTITUTIONAL ARRANGEMENT

1. The Agency specified in Article 1 of this Regulation shall be a specialised technical structure that will work in the Agricultural sector.
2. The Agency shall be established in one of the ECOWAS countries and shall have a Headquarters Agreement which shall vest on it all privileges accorded an international institution in conformity with the ECOWAS General Convention on Privileges and Immunities of 1978.
3. It shall have administrative and financial autonomy and its rules of procedure, legal, administrative and financial operating regulations shall be (staff regulations, administrative and financial

management procedures) in conformity with those enforced in ECOWAS.

4. The Commissioner for Agriculture, Environment and Water Resources shall supervise RFAA on behalf of the President of the ECOWAS Commission.

ARTICLE 3 MANDATE AND MISSION

1. The mandate of the Agency is to ensure the technical implementation of programs and regional investment plans and contribute to the operationalization of the ECOWAS agricultural policy, by working with regional institutions, agencies and stakeholders with proven expertise.
2. The functions shall include:
 - a) To enhance the intervention capacity of the ECOWAS Commission, particularly the Department for Agriculture, Environment and Water Resources, reinforcing its technical capacity to implement investment programs and enable it provide strategic orientation, regulation and control.
 - b) To contribute in the capacity building of the regional actors in document preparation and implementation of activities and help improve the various services provided by the technical cooperation institutions and other regional actors undertaking activities in the agricultural sector (private sector, professional agricultural organisations and civil society).
 - c) To coordinate and streamline the activities of the specialized technical institutions in the agricultural and agro-food sectors.

ARTICLE 4 OPERATIONS

1. The Agency shall submit, for approval, requests for financing to the managers of the Regional Food and Agriculture Fund established by Council Regulation C/REG.2 108/11.
2. The Agency shall request for technical advice from the Advisory Committee on Food and Agriculture established by Council Regulation C/REG.3/08/11 and from an Inter-departmental

Committee to be established by the President of the Commission.

ARTICLE 5 OPERATING STRUCTURES

The Agency shall comprise one *executive* Directorate under which two operational units shall be established: the administration and finance unit and the technical unit for implementation of the programmes.

ARTICLE 6 FUNCTIONS OF THE EXECUTIVE DIRECTORATE

1. The Executive Directorate shall be responsible for the management of the Agency, and shall manage relations with the Department of Agriculture, Environment and Water Resources, as well as other structures involved in the implementation of the agricultural policy, technical cooperation institutions, (Regional Advisory Committee and the inter-department) other Producers and socio-professional organisations, civil society and all other regional actors that contribute towards achieving the goal of ECOWAP.
2. The Executive Directorate shall coordinate the preparation of programme budget estimates for submission to the ECOWAS Statutory Authorities through the Commissioner for Agriculture, Environment and Water Resources.
3. The Executive Directorate shall receive and centralise the projects and programmes jointly financed and submitted to the Agency for implementation by the Member States, technical institutions, other regional actors and banks prior to submitting these to the ECOWAF Food and Agricultural Fund (ECOWADF) managers.
3. The Executive Directorate shall ensure proper functioning of the Agency and shall submit reports on its activities to the ECOWAS statutory authorities.
5. The Executive Directorate shall organize financial and technical audits on the Agency and submit same to the President of the Commission through the Department of Agriculture, Environment and Water Resources.

ARTICLE 7 FUNCTIONS OF THE ADMINISTRATION AND FINANCE UNIT

1. The Administration and Finance Unit shall be under the authority of the Executive Directorate and shall be responsible for the management of administrative and financial affairs.
2. It shall ensure compliance of the administrative and financial actions undertaken by the Agency with the relevant rules and regulations enforced in ECOWAS.
3. It shall keep the Agency's accounts, prepare, sign and monitor contracts signed with the partner institutions.
4. It shall manage the human resources of the Agency and be in charge of Staff Welfare.
5. It shall ensure compliance with all Protocols signed with partner institutions on matters that fall within its purview.

ARTICLE 8 FUNCTIONS OF THE TECHNICAL UNIT

1. The Technical Unit in charge of programme implementation shall collaborate in the development of policy instrument aimed at stimulating agricultural production. It shall coordinate the technical implementation of investment programmes and the establishment of policy incentives for agricultural production.
2. The Unit shall ensure the proper execution of all planned activities. To that end, it shall undertake two categories of tasks: appropriate preparation of the programme documents and regular monitoring of the status of implementation of the activities by different service providers.
3. The Unit shall undertake capacity building of the Institutions and all actors eligible to directly execute activities under the three specific objectives of the Regional Agricultural Investment Programme: support for the preparation of bid tenders, training of those involved in project management and issues relating to gender mainstreaming and the environment.
4. Regarding monitoring, the technical unit is responsible for auditing activities to verify compliance with project or program

specifications. It may suggest, after discussion with the different stakeholders and analysis of the context, adjustments to be made.

ARTICLE 9 STAFFING

The staffing of the Agency as well as the matching job profiles as contained in the detailed "Note on the institutional mechanism and financial arrangements for ECOWAP/CMDP implementation" attached to this Regulation are hereby adopted.

ARTICLE 10 PUBLICATION

This Regulation shall be published by the ECOWAS Commission in the Official Journal of the Community within thirty (30) days after its signature by the Chairman of Council. It shall also be published by each Member State in its Official Gazette within thirty (30) days after its notification thereof by the Commission.

DONE AT ABUJA, THIS 19TH DAY OF AUGUST 2011

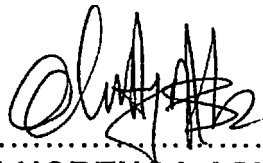

.....
H.E. OLUGBENGA ASHIRU

CHAIRMAN

FOR COUNCIL



SIXTY-SIXTH ORDINARY SESSION OF THE COUNCIL OF MINISTERS

ABUJA, 17 - 19 August 2011

REGULATION C/REG. 2/08/11 CREATING THE REGIONAL FOOD AND AGRICULTURE FUND (ECOWADF)

THE COUNCIL OF MINISTERS,

MINDFUL of Articles 10, 11 and 12 of the ECOWAS Treaty as amended, establishing the Council of Ministers and defining its composition and functions;

MINDFUL of Article 25 of the *said* ECOWAS Treaty on Agricultural Development and Food Security;

MINDFUL of Decision AIDEC.11/01/05 adopting the ECOWAS Agricultural Policy;

RECALLING the recommendation of the Extraordinary Session of the Joint Meeting of ECOWAS Ministers of Regional Integration, Agriculture, Trade, Economic Affairs and Finance held on 23rd October 2009 in Yamoussoukro on the creation of the Regional Food and Agriculture Fund;

CONSIDERING that the ECOWAS Agricultural Policy adopted in 2005 provides for intervention activities within its any components and that various structures have been established by, legal acts to undertake activities within the framework of ECOWAP;

RECOGNISING the need for the provision of funds to support the operations of these structures;

DESIROUS therefore of establishing a fund for investment in the Agricultural sector, to implement and monitor programmes derived from ECOWAP;

ON THE RECOMMENDATION of the meeting of the Specialised Ministerial Committee on Agriculture, Environment and Water Resources held on 3rd February 2011 in Accra, Ghana;

EN ACT S:

ARTICLE 1

This Regulation hereby creates the Regional Food and Agriculture Fund (ECQWADF).

ARTICLE 2

1. The Regional Food and Agriculture Fund referred to in Article 1 of this Regulation assures funding for the regional investment programmes being implemented by the Regional Food and Agriculture Agency by channeling all domestic and foreign resources towards financing the ECOWAS/CAADP regional programmes.
2. It shall supplement the national financing arrangements put in place by ECOWAS Member States to ensure financing of the National Agricultural Investment Programmes (NAIP).

ARTICLE 3

1. The Fund shall be managed by the ECOWAS Bank for Investment and Development (EBID) under a Delegation Agreement establishing the rules and procedures jointly defined by the ECOWAS Commission and EBID.
2. Accordingly, the Regional Food and Agriculture Fund shall be established within the EBID premises in Lome, Togolese Republic.

ARTICLE 4

This Regulation shall be published by the ECOWAS Commission in the Official Journal of the Community within thirty (30) days after its date of signature by the Chairman of the Council of Ministers. It shall also be published by each Member State in its Official Journal within thirty (30) days after its notification thereof by the Commission.

DONE AT ABUJA, THIS 19TH DAY OF AUGUST 2011

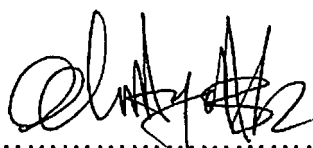

.....
H.E. OLUGBENGA ASHIRU

CHAIRMAN

FOR COUNCIL



SIXTY-SIXTH 'ORDINARY SESSION
OF THE COUNCIL OF MINISTERS

Abuja, 17.- 19 August 2011

REGULATION C/REG.3/08/11 ESTABLISHING THE ADVISORY
COMMITTEE FOR FOOD AND AGRICULTURE

THE COUNCIL OF MINISTERS,

MINDFUL of Article 10, 11 and 12 of the ECOYVAS Treaty as amended, establishing the Council of Ministers and defining its composition and functions;

MINDFUL of Article 25 of the said ECOWAS Treaty relating to Agricultural Development and Food Security;

MINDFUL of Decision A1DEC.11/01/05 adopting the ECOWAS Agricultural Policy;

RECOGNISING that the establishment of an Advisory Committee will institutionalize the multi-actor partnership initiated during the ECOWAS/CAADP process for the implementation of the Agricultural Policy;

DESIROUS of establishing the Advisory Committee for Food and Agriculture;

ON THE RECOMMENDATION of the Extraordinary Session of the joint meeting of Ministers in charge of Regional Integration, Agriculture, Trade, Economy and Finance, held in Yamoussoukro on 23 October 2009;

ENACTS

ARTICLE 1: Establishment

This Regulation hereby establishes the Advisory Committee for Food and Agriculture (ACFA) as a forum for regular consultation on all aspects relating to the implementation of ECOWAS/CAADP.

ARTICLE 2: Composition

1. The composition of the Advisory Committee for Food and Agriculture (ACFA) shall reflect a fair representation of Member States' representatives, professional organisations (farmers' organisations and private food-processing industries), regional cooperation organisations and technical and financial partners.

2. The ACFA shall comprise:

a) Representatives of ECOWAS Institutions, namely:

- i) President of the Commission;
- ii) Commissioner for Agriculture, Environment and Water Resources;
- iii) Representative of the ECOWAS Parliament, and
- iv) Director of Agriculture and Rural Development;

b) Representatives of Member States from the Ministries of Agriculture and ECOWAS Affairs:

c) Representatives of professional organisations, namely:

- i. Four representatives of professional farmers' organisations;
11. Two representatives of the Regional Network of Chambers of Agriculture;

- iii. Two representatives of the private food-processing industries;

d) A Representative from each of the regional Institutions below:

- i. Comite permanent Inter-etats de Lutte contre la Secheresse (CILSS)
- ii. West African Economic Monetary Union (UEMQA)
- iii. La Conference des Ministres de l'Agriculture de l'Afrique de l'Ouest (CMAAOC)
- iv. Conseil Quest et Centre Africain pour la Recherche et le Developpement Agricoles (CQRAF)
- v. Africa Rice Centre
- vi. International Institute of Tropical Agriculture (IITA)
- vii. Rural Hub.

e) Three representatives of technical and financial partners appointed from the Tradition Famille Propriete (TFP) coordinating group;

f) Two representatives of NGOs supporting agricultural development;

g) Other invited or resource persons from within or outside the region. Invited by Chairman of ACFA depending on the subject matter.

3. The Committee shall be chaired by the Minister of Agriculture of the country at the chairmanship of ECOWAS at the given time.

4. A representative of the professional farmers' organisations shall be the Vice Chairman of the Committee.

5. The Department of Agriculture, Environment and Water Resources of the ECQWAS Commission shall provide secretarial services for ACFA.

ARTICLE 3: Mandate

The Advisory Committee for Food and Agriculture shall advise on all issues relating to the implementation of the ECOWAS Agricultural Policy (ECOWAP/CAADP). It shall:

- a. Advise on ECOWAP/CAADP orientations;
- b. Advise on the annual plan of action of the Regional Investment Programmes;
- c. Advise on budgetary orientations;
- d. Review the annual monitoring and evaluation report, the report of the implementation of the Regional Fund for Food and Agriculture;
- e. Submit to the ECOWAS Commission, any matter members may consider relevant within the framework of the ECOWAP/CAADP operationalisation;
- f. Provide a forum for discussions on the initiatives of various stakeholders;
- g. Monitor the implementation of the Regional Partnership Agreement.

ARTICLE 4: Operation

1. The Committee shall meet once (1) a year at the invitation of its Chairman.
2. The meeting shall be scheduled based on the timetable for the preparation of the Regional Investment Programme (RAIP) Annual Operational Plan, before submission to ECOWAS decision-making bodies.
3. Its operational costs shall be charged to the budget of the Department of Agriculture, Environment and Water Resources.

ARTICLE 5: Publication

This Regulation shall be published by the ECOWAS Commission in the Official Journal of the Community within thirty (30) days after its date of signature by the Chairman of the Council of Ministers. It shall also be published by each Member State in its Official Journal within thirty (30) days after its notification thereof by the Commission.

DONE AT ABUJA, THIS 19TH DAY OF AUGUST 2011

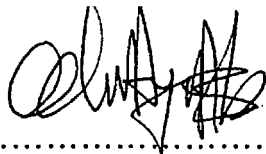

.....
H.E. OLUGBENGA ASHIRU

CHAIRMAN
FOR COUNCIL



SIXTY-SIXTH ORDINARY SESSION
OF THE COUNCIL OF MINISTERS

Abuja, 17 - 19 August 2011

REGULATION C/REG.4/08/11 ON THE VALIDATION OF THE
STRATEGIC ACTION PLAN FOR THE DEVELOPMENT AND
TRANSFORMATION OF LIVESTOCK FARMING IN WEST AFRICA

THE COUNCIL OF MINISTERS,

MINDFUL of Articles 10, 11 and 12 of the ECOWAS Treaty as amended, relating to the establishment of the Council of Ministers and defining its composition and functions;

MINDFUL of Article 25 of the said ECOWAS Treaty on Agricultural Development and Food Security;

MINDFUL of Decision *AIDEC.11/01/05* adopting the ECOWAS Agricultural Policy;

MINDFUL of Decision *C/DEC.1/5/81* on the components of the fight against hunger, multiplication of certain varieties of plant and animal species, funding of research programs and project for agricultural production, storage and treatment of agricultural products;

MINDFUL of Decision *NDEC/5/10/98* of the Authority of the Heads of States and Government of transhumance within the ECOWAS region;

MINDFUL of the Supplementary Act *AISA/12/01/07* on establishment of a sub-regional mechanism of coordination of the prevention and Response against Avian Influenza in West Africa;

MINDFUL of Directive C/DIR.1/11/10 on the ECOWAS Veterinary Pharmacy;

MINDFUL of regulation C/REG.21/11/10 on harmonizing the structure and the operating rules in security and protection of plants, animals and fruits;

MINDFUL of Regulation C/REG. 22/11/10 on the Procedure for the management of veterinary medicine;

MINDFUL of Regulation C/REG.23/11/10 on the establishment, composition and modalities of operation of the Veterinary Regional Committee within ECOWAS;

MINDFUL of the Maputo declaration which obliges African countries to allocate 10% of their budgets to fund agricultural matters;

CONSIDERING that livestock constitutes a major component of ECOWAP for which veterinary structures and organs have been established;

CONVINCED by the need of adopting a regional plan of action for the implementation and monitoring of programmes and activities relating to the development of livestock;

ON RECOMMENDATION of the meeting of ECOWAS Agriculture and Livestock Ministers which was held on 10 March 2011 at Bamako, Republic of Mali;

ENACTS

ARTICLE 1

The Strategic Action plan for the Development and Transformation of Livestock Farming in West Africa attached to the Regulation is hereby adopted.

ARTICLE 2

1. The ECOWAS Commission shall take necessary measures for the implementation of the Strategic Action Plan for the Development and Transformation of Livestock Farming in West Africa.

2. The President of the Commission through the Commissioner for Agriculture, Environment and Water Resources shall monitor the implementation of the Strategic Plan of Action.

ARTICLE 3

This Regulation shall be published by the ECOWAS Commission in the Official Journal of the Community within thirty (30) days of its signature by the Chairman of the Council of Ministers. It shall also be published by each Member State in its Official Journal within the same time frame after due notification by the Commission.

DONE AT ABUJA, THIS 19TH DAY OF AUGUST 2011

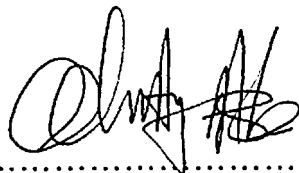

.....
H.E. OLUGBENGA ASHIRU

CHAIRMAN

FOR COUNCIL



SIXTY-SIXTH ORDINARY SESSION OF THE COUNCIL OF MINISTERS

Abuja, 17 - 19 August 2011

REGULATION C/REG.5/08/11 RELATING TO THE DENOMINATION AND THE ESTABLISHMENT OF THE RULES FOR THE FUNCTIONS, ORGANIZATION AND MODE OF OPERATION OF THE ECOWAS PROJECT PREPARATION AND DEVELOPMENT UNIT (PPDU)

THE COUNCIL OF MINISTERS,

MINDFUL of Articles 10, 11 and 12 of the ECOWAS Treaty as amended, establishing the Council of Ministers and defining its composition and functions;

MINDFUL of the provisions of Article 28 of the said Treaty relating to the coordination and harmonisation of policies and programmes in the field of energy;

MINDFUL of the provisions of Article 32 of the said Treaty on the coordination and harmonisation of policies and programmes in the field of transport;

MINDFUL of Protocol AIP117/96 on the conditions governing the application of the Community Levy;

MINDFUL of Supplementary Act *AISA.6/01/08* amending Decision *AIDEC.9/01/06* on the allocation of resources from the Community Levy to Community Institutions;

MINDFUL of Regulation C/REG.9/12/99 approving the restructuring of the ECOWAS Executive Secretariat in order to make it more functional and to pursue ECOWAS and NEPAD objectives, thereby fulfilling the expectations of Member States;

MINDFUL of Regulation C/REG.18/01/05 of 18 January 2005 relating to the creation within the ECOWAS Executive Secretary of a Project Development and Implementation Unit (PDIU) for the Development and Implementation of NEPAD Infrastructure Projects;

DESIROUS of amending, by this Regulation, the provisions of Regulation C/REG.18/01/05 of 18 January 2005 to make the said provisions consistent with the texts establishing the PPDU;

MINDFUL of Regulation C/REG.18/11/08 of 29 November 2008 relocating the ECOWAS Project Preparation and Development Unit (PPDU) to ECOWAS Bank for Investment and Development (EBID) and establishing the Infrastructure Fund for financing the activities of the Unit;

BEARING IN MIND that the term "PPDU" is commonly used by various stakeholders in the infrastructure sector and that the said term may be retained as the designation for the Project Preparation and Development Unit;

OBSERVING that the term "POIU" has changed to become "PPDU" for reasons of the partial change in the mandate and responsibilities of the Unit;

CONSIDERING the imperative need to define the organisation, functions and mode of operation of the Project Preparation and Development Unit to facilitate the take-off of its activities;

CONSIDERING that, upon the creation of the PPDU, a Working Group comprising ECOWAS Commission and its technical and financial partners was established, and that the said Group affirmed the importance of conferring autonomy on the PPDU;

DESIROUS therefore of adopting Regulations to govern the organisation, functions and mode of operation of the PPDU;

ON THE RECOMMENDATION of the ninth meeting of the Administration and Finance Committee held in Abuja in May 2011;

ENACTS:

CHAPTER 1: DEFINITIONS, DENOMINATION, FUNCTIONS,
ORGANISATION AND MODE OF OPERATION OF
THE PPDU

Article 1 Definitions

For the purpose of these Regulations, and unless the context otherwise dictates:

"Treaty" means the Revised Treaty of the Economic Community of West African States (ECOWAS) signed in Cotonou on 24 July 1993 and all its amendments;

"ECOWAS" means the Economic Community of West African States, established under Article 2 of the 1993 Revised Treaty of ECOWAS;

"Unit" means the Project Preparation and Development Unit (PPDU);

"Community" means the Economic Community of West African States (ECOWAS) referred to under Article 2 to the revised Treaty and subsequent protocols;

"Commission" means the ECOWAS Commission established by virtue of the New Article 17 of the Supplementary Protocol AISP.1/06/06 amending the Revised Treaty;

"Director" means Director of PPDU

"Member States" means the Member States of ECOWAS;

"Council of Ministers" means the Council of Ministers as established by Article 10 of the ECOWAS Revised Treaty;

"NEPAD" means the New Partnership for Africa's Development:

"Technical and Financial Partners" means the donors and development partners which support PPDU activities through financing, technical assistance and capacity building;

"The Advisory Facility" (AF): means the facility support to the public sector or in some cases the private sector in partnership with the public sector;

"The Infrastructure Developer Challenge Fund" (IDCF): means the facility provided for the funding of the operations of projects preparation of the private sector.

"Stakeholder" means all entities that will benefit from the activities of the PPDU and/or have provided a financial contribution or technical assistance to it.

Article 2 Denomination

1. The NEPAD Infrastructure Projects Development and Implementation Unit (PDIU) established in the ECOWAS Commission is hereby re-designated Project Preparation and Development Unit (PPDU).
2. The PPDU shall be vested with legal personality and the autonomy necessary to discharge its mandate.

Article 3 Functions of the PPDU

1. The PPDU shall be responsible for:
 - a. preparing and developing regional integration infrastructure projects in ECOWAS Member States;
 - b. management of a dedicated infrastructure fund for preparation of the projects;
 - c. promotion of public/private partnerships in investment financing and project management in ECOWAS;
 - d. discharging such other tasks as may be assigned to it by its governance organs.

2. To this end, the PPDU shall:

- a) Identify, select and prioritize regional integration infrastructure projects in consultation with the ECOWAS Commission, Member States and the private sector;
- b) Mobilise the resources required for preparation and development of infrastructure projects;
- c) Undertake the studies and activities required for preparation and development of infrastructure projects with a view to making the projects bankable;
- d) Create a more attractive climate for regional infrastructure projects financing and investment;
- e) Manage the Infrastructure Funds, and all the other Funds placed at its disposal;
- f) Serve as regional focal point for capacity-building of similar structures in ECOWAS Member States;
- g) Negotiate and conclude cooperation and/or partnership agreements with regional and sub-regional institutions in the area of infrastructure project preparation and development.
- h) Monitor and evaluate the implementation of projects it supports.

Article 4 Governance organs

The governance organs of the PPDU shall be:

- The Steering Committee; and
- The Directorate.

Article 5 Composition and Functions of the Steering Committee

The Steering Committee shall be the strategic decision-making organ of the PPDU.

1. Composition of the Steering Committee

- a) The Steering Committee shall be composed of the following nine (9) members representing PPDU stakeholders:
 - i. Two (2) Representatives of the ECOWAS Commission;
 - ii. One (1) Representative of the ECOWAS Bank for Investment and Development (EBID);
 - iii. Two (02) Members representing ECOWAS Member States;
 - iv. Three (03) Members representing the Technical and Financial Partners; and
 - v. One (01) Member representing the Private Sector.
- b) One of the Representatives of ECOWAS Commission shall be the Chairperson of the Steering Committee. The Deputy Chairperson shall be elected by Members of the Steering Committee.
- c) Members of the Steering Committee shall be persons recognised for their technical and managerial competence.
- d) The Director of PPDU shall participate in meetings of the Steering Committee in a non-voting capacity.

2. Functions of the Steering Committee

The Steering Committee shall perform the following functions:

- a) Propose from time to time for adoption by ECOWAS Statutory Authorities the overall mandate and management policy of the PPDU;
- b) Approve the operating strategy of the PPDU;
- c) Appoint External Auditors and review and approve the annual audited financial accounts;

- d) Approve the annual operating plan and budget submitted by the PPDU Management;
- e) Approve the organisational structure of the PPDU;
- f) Appoint the Director, evaluate his/her performance and, if need be, terminate his/her appointment;
- g) Approve the appointment proposal for the senior management staff of the PPDU;
- h) Approve the applications for the Advisory Facility (AF) and the Infrastructure Developer Challenge Fund (IDCF);
- i) Approve PPDU Management submissions in respect of distribution/allocation of AF and IDCF;
- j) Approve the commitments and expenditures of the AF and the IDCF;
- k) Approve the risk management plan, financial audit and control procedures of the PPDU;
- l) Approve the Rules of Procedure and the Manuals of Accounting, Financial, Administrative and Human Resource Management Procedures of the PPDU;
- m) Monitor the performance of the PPDU in relation to its mandate;
- n) Review the performance of the PPDU from time to time and make appropriate recommendations to the statutory authorities of ECOWAS. The periodicity for review shall be specified in the Manual of Procedure.

Article 6 Mode of Operation of the Steering Committee

- a) The Steering Committee shall hold two (2) ordinary sessions in a calendar year, and an extra-ordinary session (s) where the need arises, at the invitation of its Chairperson or at the instance of at least two-thirds (2/3) of its members. The Chairperson shall address a written notification to each member not later than fifteen (15) days before any of the meetings.

- b) The Deputy Chairperson shall stand in for the Chairperson:
- At the request of the Chairperson; or
 - Where the Chairperson is unable to carry out his/her duties.
- c) In case of vacancy of the position of Deputy Chairperson, the Chairperson shall provisionally appoint a member of the Steering Committee to serve as Deputy Chairperson until the next meeting of the Committee at which a new Deputy Chairperson shall be appointed.
- d) Two-thirds (2/3) of the Steering Committee shall constitute a quorum. Decisions of the Steering Committee shall be taken by a simple majority of the members present and voting. In the event of a tie, the Chairperson shall have a casting vote.
- e) The deliberations of the Steering Committee shall be recorded in a report signed by its Chairperson and the designated Rapporteur.
- f) The PPDU Directorate shall serve as the Secretariat of the Steering Committee.
- g) Members of the Steering Committee shall receive sitting allowance as prescribed in the PPDU Manual of Procedures referred to under Article 9 of this Regulation. Their participation in the various sessions shall be covered by the budget of the PPDU.
- i) The Steering Committee may set up technical committees whenever necessary.

Article 7 Election and Term of Office, Resignation and Removal, Vacancy of Position

1. Election and Term of Office

- a) With the exception of the Representatives of the ECOWAS Commission and those of EBID, members of the Steering Committee shall be appointed for a non-renewable tenure of four (4) years with effect from the date of their appointment.

- b) The Representatives of ECOWAS Commission, namely: the Commissioner for Infrastructure and the Commissioner for Finance and Administration or their respective representatives, shall be appointed in their official capacity.
- c) The Representative of EBID, namely, the Vice President in charge of Operations or his/her Representative shall be appointed in his/her official capacity.
- d) Representatives of Member States shall be appointed by consensus from among ECOWAS Member States on a two (2) year rotational basis.
- e) Without prejudice to Article 11 (2) of this Regulation the procedure for appointing representatives of the Steering Committee with the exception of the representatives of the ECOWAS Commission and EBID shall be defined in a regulation to be adopted by the Steering Committee established under Article 3 of this Regulation.

2. Resignation and Removal from Office

- a) Any member wishing to resign from the Steering Committee shall give fifteen (15) days notice thereof to the Chairperson of the Steering Committee who shall inform the other members accordingly.
- b) A member of the Steering Committee may be removed from office for dereliction of duty, gross misconduct, repeated unjustified absence from committee sessions or where he/she has been convicted of a criminal offence, in accordance with the Rules of Procedure of the Committee.
- c) In case of resignation, death or removal from office of a member of the Steering Committee, his/her replacement shall be chosen without prejudice to the composition of the Steering Committee.

3. Vacancy of position

Where the position of a member of the Steering Committee becomes vacant during his/her tenure, the Chairperson of the Steering Committee shall take all appropriate measures for

replacement of the member without prejudice to the composition of the Steering Committee.

Article 8 Directorate of the PPDU

1. Functions of the Director

The Director shall:

- a) Act as the principal representative of the PPDU in its dealings with all the key stakeholders;
- b) Implement the decisions of the Steering Committee;
- c) Represent the PPDU in all contractual transactions and act as its legal representative.
- d) Initiate and conduct staff recruitment in conformity with the organizational structure and the relevant procedures, as adopted by the Steering Committee;
- e) Organise and coordinate all activities of the PPDU;
- f) Manage the assets of the Unit;
- g) Sign contracts within the limits set by the Steering Committee;
- h) Authorize expenditure within the limits set by the Steering Committee;
- i) Recruit experts and consultants to render services relating to the effective running of the Unit, depending on the workload of the relevant staff;
- j) Manage and supervise the staff of the PPDU in the execution of their day-to-day activities and report to the Steering Committee;
- k) Build a good image for the Unit by the quality of the projects presented;
- l) Perform such other functions as may be assigned to him/her by the Steering Committee.

2. Recruitment of the PPDU Director

- a) The profile and grade required for the position of Director of the PPDU shall be determined by the Steering Committee which shall adopt the Terms of Reference for the said position.
- b) Recruitment of the Director of the PPDU shall be conducted in a transparent manner through competitive international recruitment procedure, open only to nationals of ECOWAS Member States.
- c) The Director of the PPDU shall be recruited on account of his/her competences and experience in infrastructure project management as defined in the profile of the position.
- d) In collaboration with the appropriate Human Resource Committee of the ECOWAS Commission, three (3) members of the Steering Committee shall participate in the process of selecting the Director.
- e) The Director of the PPDU shall be appointed by the Steering Committee for a tenure of five (5) years, renewable once.
- f) The personal emoluments of the Director shall be determined by the Steering Committee and shall be competitive in relation to comparable institutions.
- g) Renewal of the tenure of the Director shall be subject to an evaluation of his/her performance by the Steering Committee. The Steering Committee shall decide whether or not to renew the tenure of the Director depending on the outcome of the evaluation.

Article 9 Staff of the PPDU

1. The PPDU staff complement shall comprise of a Director, a technical team and support administrative staff recruited on the basis of the organizational structure and the PPDU Staff Regulations adopted by the Steering Committee.
2. Recruitment shall be carried out in collaboration with the appropriate Human Resources Committee of the ECOWAS Commission.

Article 10 Manuals of Procedure and Rules of Procedure

1. The rules governing the operation of the PPDU shall be set out in the Manuals of Procedure and Operation adopted by the ECOWAS Council of Ministers on the recommendation of the Steering Committee.
2. The Steering Committee shall adopt its own Rules of Procedure

Article 11 Communication

The PPDU shall devise a communication policy with a view to promoting and ensuring the transparency of its activities. It shall publish a report on its activity, on annual basis.

CHAPTER 2: FINANCIAL AND ACCOUNTING PROVISIONS

Article 12 Funding and Utilization

1. The PPDU shall be financed by contributions from the stakeholders. The funds so raised shall be used to finance:
 - a. The Infrastructure Fund; and
 - b. The operating budget.
2. The Infrastructure Fund
 - 1) The Infrastructure Fund shall comprise two types of Fund: the Advisory Facility (AF) and the Infrastructure Developer Challenge Fund (IDCF).
 - 2) The sources of funding for the Infrastructure Fund shall be:
 - a) The Community;
 - b) Donors, contributors, foundations and development partners;
 - c) Public-private sector partnership mechanisms; and
 - d) All other sources.

3. The Advisory Facility (AF):

The Advisory Facility shall serve to provide support to the public sector in the form of technical assistance towards preparation and negotiation of infrastructure projects. The Facility shall also be used to support the public sector during project preparation and negotiation with the private sector.

4. The Infrastructure Developer Challenge Fund (IDCF)

a. The IDCF shall serve to provide support towards development of private sector-led infrastructure projects emanating from public-private partnership.

5. Common procedures of the two funds

b. Distribution of the funds shall be determined by the Steering Committee.

c. The procedure for use as well as the criteria for accessing the AF and the IDCF shall be established by the PPDU Directorate and approved by the Steering Committee.

d. For both the AF and the IDCF, there shall be open invitations for the tendering of proposals from ECOWAS Member States' Governments and private sector regarding the provision of grants and/or contributions towards the cost of infrastructure projects.

6. Operating Budget

The Operating budget of the PPDU shall be made up of resources as a determined by the Steering Committee of the PPDU.

7. Adoption of PPDU Budget

The budget for the upcoming year shall be adopted by the Steering Committee in the last quarter of the current year.

Article 13 Financial Regulations of the PPDU

1. The PPDU shall provide itself with Financial Regulations and a Manual of Accounting Procedures approved by the Steering Committee.
2. The Financial Regulations referred to in paragraph 1 of this article shall be in conformity with the ECOWAS Financial Regulation and Manual of Accounting Procedures.

CHAPTER 3: TRANSITIONAL AND FINAL PROVISIONS

Article 14 Transitional Provisions

- 1.a) For the purpose of speedy takeoff of the activities of the PPDU, interim personnel shall be recruited for the Unit on one-year renewable contract. The said recruitment shall be undertaken under the supervision of the President of the ECOWAS Commission. A Recruitment Committee is hereby established, with membership comprising the Representatives of ECOWAS Commission (Infrastructure Department, Human Resources Directorate), financial and technical partners, and two resource persons recognized for their competence in infrastructure development.
- 1.b) The Committee shall select the candidates on the basis of a fair, transparent and competitive process.
2. The appointment of the Steering Committee members shall be undertaken under the supervision of the President of ECOWAS Commission in consultation with the stakeholders.
3. The operating budget of US\$8.864 million appropriated by the Council of Ministers by Regulation *C/REG.18/11/08* of 29 November 2008, for a period of five years, shall be reallocated for five (5) years with effect from the date of signing of this Regulation.
4. The Infrastructure Fund shall start off with the sum of US\$ten (10) million as per Regulation *C/REG.18/11/08* of 29 November 2008 adopted by the ECOWAS Council of Ministers. Other project funding needs shall be met by this Fund, as well as by the donors

and development partners participating in the financing of the PPDU.

Article 15 Final Provisions

1. *This* Regulation abrogates all contrary previous provisions, particularly the provisions of Regulation C/REG.18/01/05 of 18 January, 2005 establishing within the ECOWAS Executive Secretariat, a Unit for the development and implementation of NEPAD infrastructure projects.
2. It shall be published by ECOWAS Commission in the Official Journal of the Community within thirty (30) days of its signature by the Chairman of the Council of Ministers. It shall also be published by each Member State in its National Gazette within thirty (30) days after notification by the Commission.

Done at Abuja this 19th day of August 2011

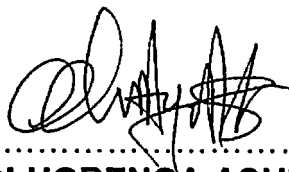

.....
H.E. OLUGBENGA ASHIRU

CHAIRMAN

FOR COUNCIL



SIXTY FIFTH ORDINARY SESSION OF THE COUNCIL OF MINISTERS

Abuja, 17 - 19 August 2011

REGULATION C/REG.6/8/11 APPROVING THE 2010 AUDITED FINANCIAL STATEMENTS OF THE ECOWAS COMMISSION

:THE COUNCIL OF MINISTERS,

MINDFUL of Articles 10, 11 and 12 of the ECOWAS Treaty as amended, establishing the Council of Ministers and defining its composition and functions;

MINDFUL of Article 75 of the Treaty appointing the External Auditors of the ECOWAS Institutions;

MINDFUL of Regulation C/REG.5/05/09 of 27th May 2009 relating to the Financial Regulation of ECOWAS Institutions;

MINDFUL of Decision AIDEC.1/07/10 of 2nd July 2010 relating to the renewal of the contract of the Firm Deloitte et Touche Côte d'Ivoire as External Auditors of the Community Institutions;

MINDFUL of the contract between ECOWAS and the Firm Deloitte et Touche Côte d'Ivoire relating to the conditions of service of the Internal Auditors of the Community Institutions;

AFTER CONSIDERING the report of the firm, « Deloitte and Touche, Cote d'Ivoire », on the 2010 financial statements of the Community Parliament;

ON THE RECOMMENDATION of the twentieth meeting of the Audit Committee, held in Abuja from 11 to 15 August 2011;

ENACTS

ARTICLE 1er :

The audited financial statements of the ECOWAS Commission for 2010 is hereby approved.

ARTICLE 2:

This Regulation shall be published by the ECOWAS Commission in the Official Journal of the Community within thirty (30) days after its date of signature by the Chairman of the Council of Ministers. It shall also be published by each Member State in its Official Journal within thirty (30) days after its notification thereof by the Commission.

DONE AT ABUJA, THIS 19TH DAY OF AUGUST 2011

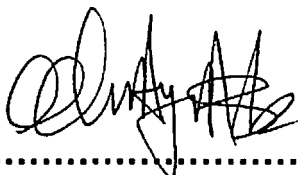

.....
H.E. OLUGBEN A ASHIRU

CHAIRMAN

FOR COUNCIL



SIXTY FIFTH ORDINARY SESSION OF THE COUNCIL OF MINISTERS

Abuja, 17 - 19 August 2011

REGULATION C/REG.7/8/11 APPROVING THE 2010 FINANCIAL STATEMENTS OF THE COMMUNITY LEVY MANAGED BY THE ECOWAS COMMISSION

THE COUNCIL OF MINISTERS,

MINDFUL of Articles 10, 11 and 12 of the ECOWAS Treaty as amended, establishing the Council of Ministers and defining its composition and functions;

MINDFUL of the provisions of Article 72 of the said Treaty relating to Community Levy;

MINDFUL of Article 75 of the Treaty appointing the External Auditors of the ECOWAS Institutions;

MINDFUL of the Protocol A1P1/7/96 relating to the conditions of application of the Community Levy;

MINDFUL of Decision A1DEC.10/11/03 relating to the report of 1st July 2003 of the day of full entry into force of the Community Levy;

MINDFUL of Decision A1DEC.9/01/06 on transfer of resources of the Community Levy to the Community Institutions;

MINDFUL of Supplementary Act AISA.6/01/08 amending the Decision AIDEC.9/01/06 on transfer of resources of the Community Levy to Community Institutions;

MINDFUL of Resolution A1RES.1/8/97 relating to the urgent implementation of the Community Levy;

MINDFUL of Regulation C/REG.5/05/09 of 27th May 2009 relating to the Financial Regulation of ECOWAS Institutions;

MINDFUL of Decision AIDEC.1/07/10 of 2nd July 2010 relating to the renewal of the contract of the firm, "Deloitte et Touche of Côte d'Ivoire, as External Auditors of the Community Institutions;

MINDFUL of the contract between ECOWAS and the firm, "Deloitte et Touche of Côte d'Ivoire", relating to the conditions of service of the Internal Auditors of the Community Institutions;

AFTER CONSIDERING the report of the firm, "Deloitte et Touche of Côte d'Ivoire", on the 2010 financial statements of the Community Parliament;

ON THE RECOMMENDATION of the twentieth meeting of the Audit Committee, held in Abuja from 11 to 15 August 2011;

ENACTS

ARTICLE 1:

The audited financial statements of the Community Levy for 2010 is hereby approved.

ARTICLE 2:

This Regulation shall be published by the ECOWAS Commission in the Official Journal of the Community within thirty (30) days after its date of signature by the Chairman of the Council of Ministers. It shall also be published by each Member State in its Official Journal within thirty (30) days after its notification thereof by the Commission.

DONE AT ABUJA, THIS 19TH DAY OF AUGUST 2011

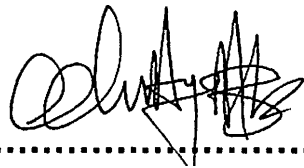

.....
H.E. OLUGBEN A ASHIRU

CHAIRMAN

FOR COUNCIL



SIXTY FIFTH ORDINARY SESSION OF THE COUNCIL OF MINISTERS

Abuja, 17 - 19 August 2011

REGULATION C/REG.8/8/11 APPROVING THE 2010 AUDITED FINANCIAL STATEMENTS OF THE COMMUNITY PARLIAMENT

THE COUNCIL OF MINISTERS,

MINDFUL of Articles 10, 11 and 12 of the ECOWAS Treaty as amended, establishing the Council of Ministers and defining its composition and functions;

MINDFUL of Article 75 of the Treaty appointing the External Auditors of the ECOWAS Institutions;

MINDFUL of Regulation C/REG.5/05/09 of 27th May 2009 relating to the Financial Regulation of ECOWAS Institutions;

MINDFUL of Decision AIDEC.1/07/10 of 2nd July 2010 relating to the renewal of the contract of the firm, "Deloitte et Touche of Côte d'Ivoire", as External Auditors of the Community Institutions;

MINDFUL of the contract between ECOWAS and the Firm Deloitte et Touche Côte d'Ivoire relating to the conditions of service of the Internal Auditors of the Community Institutions;

AFTER CONSIDERING the report of the firm, "Deloitte et Touche of Côte d'Ivoire", on the 2010 financial statements of the Community Parliament;

ON THE RECOMMENDATION of the twentieth meeting of the Audit Committee, held in Abuja from 11 to 15 August 2011;

ENACTS

ARTICLE 1:

The audited financial statements of the Community Parliament for 2010 is hereby approved.

ARTICLE 2:

This Regulation shall be published by the ECOWAS Commission in the Official Journal of the Community within thirty (30) days after its date of signature by the Chairman of the Council of Ministers. It shall also be published by each Member State in its Official Journal within thirty (30) days after its notification thereof by the Commission.

DONE AT ABUJA, THIS 19TH DAY OF AUGUST 2011

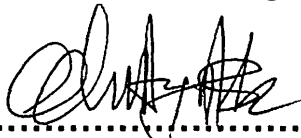

.....
H.E. OLUGBEN A ASHIRU

CHAIRMAN

FOR COUNCIL



SIXTY FIFTH ORDINARY SESSION OF THE COUNCIL OF MINISTERS

Abuja, 17 - 19 August 2011

REGULATION C/REG.9/8/11 APPROVING THE 2010 AUDITED FINANCIAL STATEMENTS OF THE WEST AFRICAN HEALTH ORGANISATION (WAHO)

THE COUNCIL OF MINISTERS,

MINDFUL of Articles 10, 11 and 12 of the ECOWAS Treaty as amended, establishing the Council of Ministers and defining its composition and functions;

MINDFUL of Article 75 of the Treaty appointing the External Auditors of the ECOWAS Institutions;

MINDFUL of Regulation C/REG.5/05/09 of 27th May 2009 relating to the Financial Regulation of ECOWAS Institutions;

MINDFUL of Decision AIDEC.1/07/10 of 2nd July 2010 relating to the renewal of the contract of the firm, "Deloitte et Touche of Côte d'Ivoire", as External Auditors of the Community Institutions;

MINDFUL of the contract between ECOWAS and the firm, "Deloitte et Touche of Côte d'Ivoire" relating to the conditions of service of the Internal Auditors of the Community Institutions;

AFTER CONSIDERING the report of the firm, "Deloitte et Touche of Côte d'Ivoire", on the 2010 financial statements of the Community Parliament;

ON THE RECOMMENDATION of the twentieth meeting of the Audit Committee, held in Abuja from 11 to 15 August 2011 ;

ENACTS

ARTICLE 1:

The audited financial statements of the West African Health Organisation (WAHO) for 2010 is hereby approved.

ARTICLE 2:

This Regulation shall be published by the ECOWAS Commission in the Official Journal of the Community within thirty (30) days after its date of signature by the Chairman of the Council of Ministers. It shall also be published by each Member State in its Official Journal within thirty (30) days after its notification thereof by the Commission.

DONE AT ABUJA, THIS 19TH DAY OF AUGUST 2011

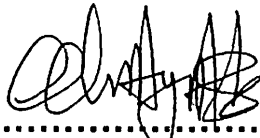

.....
H.E. OLUGBENGA ASHIRU

CHAIRMAN

FOR COUNCIL



SIXTY FIFTH ORDINARY SESSION OF THE COUNCIL OF MINISTERS

Abuja, 17 - 19 August 2011

REGULATION C/REG.10./8/11 APPROVING THE 2010 AUDITED FINANCIAL STATEMENTS OF THE INTER-GOVERNMENTAL ACTION GROUP AGAINST MONEY-LAUNDERING IN WEST AFRICA (GIABA)

THE COUNCIL OF MINISTERS,

MINDFUL of Articles 10, 11 and 12 of the ECOWAS Treaty as amended, establishing the Council of Ministers and defining its composition and functions;

MINDFUL of Article 75 of the Treaty appointing the External Auditors of the ECOWAS Institutions;

MINDFUL of Decision A1DEC.1/07/10 of 2nd July 2010 relating to the renewal of the contract of the firm, "Deloitte et Touche of Côte d'Ivoire", as External Auditors of the Community Institutions;

MINDFUL of Decision A1DEC.9/12/99 establishing the Inter-Governmental Action Group Against Money-Laundering in West Africa with its revised Status;

MINDFUL of Regulation C/REG.5/05/09 of 27th May 2009 relating to the Financial Regulation of ECOWAS Institutions;

MINDFUL of the contract between ECOWAS and the firm, "Deloitte et Touche of Côte d'Ivoire", relating to the conditions of service of the Internal Auditors of the Community Institutions;

AFTER CONSIDERING the report of the firm, "Deloitte et Touche of Côte d'Ivoire", on the 2010 financial statements of the Community Parliament;

ON THE RECOMMENDATION of the twentieth meeting of the Audit Committee, held in Abuja from 11 to 15 August 2011 ;

ENACTS

ARTICLE 1:

The audited financial statements of the Inter-Governmental Action Group Against Money-Laundering in West Africa for 2010 is hereby approved.

ARTICLE 2:

This Regulation shall be published by the ECOWAS Commission in the Official Journal of the Community within thirty (30) days after its date of signature by the Chairman of the Council of Ministers. It shall also be published by each Member State in its Official Journal within thirty (30) days after its notification thereof by the Commission.

DONE AT ABUJA, THIS 19TH DAY OF AUGUST 2011

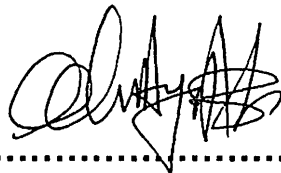

.....
H.E. OLUGBE GA ASHIRU

CHAIRMAN
FOR COUNCIL



SIXTY FIFTH ORDINARY SESSION OF THE COUNCIL OF MINISTERS

Abuja, 17 - 19 August 2011

REGULATION C/REG.11/8/11 APPROVING THE 2010 AUDITED FINANCIAL STATEMENTS OF THE ECOWAS GENDER DEVELOPMENT CENTRE

THE COUNCIL OF MINISTERS,

MINDFUL of Articles 10, 11 and 12 of the ECOWAS Treaty as amended, establishing the Council of Ministers and defining its composition and functions;

MINDFUL of Article 75 of the Treaty appointing the External Auditors of the ECOWAS Institutions;

MINDFUL of Decision AIDEC.16/04/03 relating to the transformation of the West African Women Association (WAWA) into the ECOWAS Gender Development Centre

MINDFUL of Decision A1DEC.1/07/10 of 2nd July 2010 relating to the renewal of the contract of the firm, "Deloitte et Touche of Côte d'Ivoire", as External Auditors of the Community Institutions;

MINDFUL of Regulation C/REG.5/05/09 of 27th May 2009 relating to the Financial Regulation of ECOWAS Institutions;

MINDFUL of the contract between ECOWAS and the firm, "Deloitte et Touche of Côte d'Ivoire" relating to the conditions of service of the Internal Auditors of the Community Institutions;

AFTER CONSIDERING the report of the firm, "Deloitte et Touche of Côte d'Ivoire", on the 2010 financial statements of the Community Parliament;

ON THE RECOMMENDATION of the twentieth meeting of the Audit Committee, held in Abuja from 11 to 15 August 2011;

ENACTS

ARTICLE 1:

The audited financial statements of the ECOWAS Gender Centre is hereby approved.

ARTICLE 2:

This Regulation shall be published by the ECOWAS Commission in the Official Journal of the Community within thirty (30) days after its date of signature by the Chairman of the Council of Ministers. It shall also be published by each Member State in its Official Journal within thirty (30) days after its notification thereof by the Commission.

DONE AT ABUJA, THIS 19TH DAY OF AUGUST 2011

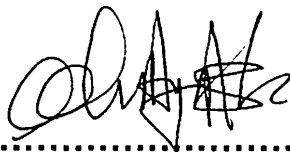

.....
H.E. OLUGBENGA ASHIRU

CHAIRMAN
FOR COUNCIL



SIXTY FIFTH ORDINARY SESSION OF THE COUNCIL OF MINISTERS

Abuja, 17 - 19 August 2011

REGULATION C/REG.12/8/11 APPROVING THE 2010 AUDITED FINANCIAL STATEMENTS OF THE ECOWAS REGIONAL CENTRE FOR RENEWABLE ENERGY AND ENERGY EFFICIENCY (ECREEE)

THE COUNCIL OF MINISTERS,

MINDFUL of Articles 10, 11 and 12 of the ECOWAS Treaty as amended, establishing the Council of Ministers and defining its composition and functions;

MINDFUL of Article 75 of the Treaty appointing the External Auditors of the ECOWAS Institutions;

MINDFUL of Decision AIDEC.1/07/10 of 2nd July 2010 relating to the renewal of the contract of the firm, "Deloitte et Touche Côte d'Ivoire", as External Auditors of the Community Institutions;

MINDFUL of AIDEC.9/12/99 establishing the Inter-Governmental Action Group Against Money-Laundering in West Africa with its revised status;

MINDFUL of Regulation C/REG.23/11/08 of 29 November 2008 establishing the ECOWAS Regional Centre for Renewable Energy and Energy Efficiency;

MINDFUL of Regulation C/REG.5/05/09 of 27th May 2009 relating to the Financial Regulation of ECOWAS Institutions;

MINDFUL of the contract between ECOWAS and the firm, "Deloitte et Touche of Côte" d'Ivoire relating to the conditions of service of the Internal Auditors of the Community Institutions;

AFTER CONSIDERING the report of the firm, "Deloitte et Touche of Côte d'Ivoire", on the 2010 financial statements of the Community Parliament;

ON THE RECOMMENDATION of the twentieth meeting of the Audit Committee, held in Abuja from 11 to 15 August 2011;

ENACTS

ARTICLE 1:

The audited financial statements of the ECOWAS Regional Centre for Renewable Energy and Energy Efficiency is hereby approved.

ARTICLE 2:

This Regulation shall be published by the ECOWAS Commission in the Official Journal of the Community within thirty (30) days after its date of signature by the Chairman of the Council of Ministers. It shall also be published by each Member State in its Official Journal within thirty (30) days after its notification thereof by the Commission.

DONE AT ABUJA, THIS 19TH DAY OF AUGUST 2011

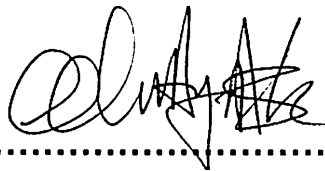

.....
H. E. OLUGBEN A ASHIRU

CHAIRMAN
FOR COUNCIL



SIXTY-SIXTH SESSION OF THE ORDINARY SESSION OF THE ECOWAS COUNCIL OF MINISTERS

Abuja, 17 - 19 August 2011

REGULATION C/REG.13/08/11 APPROVING THE RATE OF RESPONSIBILITY ALLOWANCE PAYABLE TO INTERNAL AUDITORS OF COMMUNITY INSTITUTIONS.

THE COUNCIL OF MINISTERS,

MINDFUL OF Articles 10,11 and 12 of the Revised ECOWAS Treaty establishing the Council of Ministers and laying down its membership and functions;

MINDFUL OF Regulation C/REG.11/01/05 on the payment of a responsibility allowance to Accountants and Cashiers/Imprest Officers of the .ECOWAS Institutions;

MINDFUL OF Regulation C/REG.3 2/12/07 of 15 December 2007 defining the functions of the Commissioner for Administration and Finance, the Financial Controller and Chief Internal Auditor;

MINDFUL OF Regulation C/REG.5/05/09 of 27 May 2009 adopting the Financial Regulations of the Institutions of the Economic Community of West African States (ECOWAS) ;

CONSIDERING that Regulation C/REG.11/01/05 has fixed the rate of allowance to be paid to Accountants on the basis of their responsibilities;

RECALLING that the justification for payment of responsibility allowance is based on the responsibilities incumbent on the Chief

Internal Auditors by extension, all other Internal Auditors with a view to fully or partially rectifying any impairment suffered by the ECOWAS institutions as a result of serious breaches, which is part of their remit in the accomplishment of their work;

CONSIDERING the magnitude of the responsibilities entrusted them;

DESIROUS of authorizing the payment of a responsibility allowance to the Internal Auditors at the same rate as that paid to Professional Accountants and the Controllers in the ECOWAS Institutions;

ON RECOMMENDATION by the eighth meeting of the Administration and Finance Committee held from 26 to 31 October 2010;

HEREBY ENACTS

ARTICLE 1^{ER}

It is hereby approved by this Regulation the payment of a responsibility allowance to Internal Auditors of Community Institutions.

ARTICLE 2:

The allowance shall be calculated at the rate of 15% of the basic salary of the Internal Auditors in the professional category and 100/0 for those in the general service category.

ARTICLE 3:

Payment of the approved responsibility allowance shall take retroactive effect from 1 August 201.

ARTICLE 4:

This Regulation shall be published by the ECOWAS Commission in the Official Journal of the Community within thirty (30) days of its

signature by the President of the Council of Ministers, and shall equally be published by each Member State in its Official Gazette thirty (30) days after notification by the Commission.

DONE AT ABUJA, THIS 19TH DAY OF AUGUST 2011

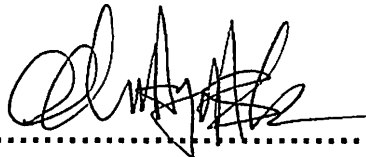

.....
H.E. OLUGBENGA ASIIRU

CHAIRMAN

FOR COUNCIL



SIXTY-SIXTH ORDINARY SESSION OF THE COUNCIL OF MINISTERS

Abuja, 17- 19 August 2011

DIRECTIVE C/DIR. 1/08/11 ON FIGHTING CYBER CRIME WITHIN ECOWAS

THE COUNCIL OF MINISTERS,

MINDFUL of Articles 10, 11 and 12 of the ECOWAS Treaty as amended, establishing the Council of Ministers and defining its composition and functions;

MINDFUL of Articles 27, 32 and 33 of the said Treaty on Science and Technology, and on the areas of Communication and Telecommunications;

MINDFUL of Article 57 of the said Treaty on judicial and legal cooperation, which provides that Member States undertake to promote judicial cooperation with a view to harmonizing judicial and legal systems;

MINDFUL of the ECOWAS Supplementary Act A1SA 1/01/07 of 19 January 2007 on the harmonization of the policies and regulatory framework of the Information and Communication Technology sector (ICT);

MINDFUL of the ECOWAS Supplementary Act *AISA.1/01/10* on Personal Data Protection within ECOWAS;

MINDFUL of the ECOWAS Supplementary Act *AISA.2/01/10* on Electronic Transaction within ECOWAS;

MINDFUL of Convention AIP 117/92 of ECOWAS relating to the Mutual Assistance in Criminal Matters;

MINDFUL of Convention AIP1/94 relating to extradition;

MINDFUL of the cooperation as regards matters of criminal policing between the member States of ECOWAS which provides the pooling of expertise and sharing of experiences by security services with a view to establishing an efficient method of police investigations;

CONSIDERING that the use of information and communication technologies, among others, the internet or cybernetics, has generated an upsurge of reprehensible acts;

NOTING that cyber crime is a new phenomenon that requires the definition of specific offences that must be substantially linked with conventional offences such as theft, swindling, the receipt of stolen goods, blackmail, and damages caused by the use of the internet;

CONSCIOUS that criminal acts committed by means of internet require the identification of a legal regime and a suitable punishment because of the level of damage they generate;

DESIROUS to adopt a framework for criminal liability in order to effectively fight against cyber crime and provide for efficient and reliable international cooperation.

HAVING OBTAINED THE OPINION of the ECOWAS Parliament dated 23 May 2009;

PRESCRIBES:

CHAPTER I

GENERAL PROVISIONS

Article 1 Definitions

. For the purposes of this Directive:

Electronic communication means making communication available to the general public or a category of the public through a process of electronic or electromagnetic means, signs, signals, written documents, images, sounds or messages of any kind;

Computer data: any representation of facts, information or concepts in a form suitable for processing in a computer system;

Racism and xenophobia in relation to ICTs refer to any document, image or any other depiction of ideas or theories, which advocates or encourages hatred, discrimination or violence against a person or group of persons by reason of their race, colour, ancestry, affiliation or their national or ethnic origin or religion, to the extent that this reason serves as a pretext for one or the other of such elements or incites such acts;

Minor: any person under the age of eighteen (18) as stipulated in the United Nations Convention on the Rights of the Child;

Child pornography: any data of whatever nature or form, that visually depicts a minor engaged in a sexually explicit conduct or realistic images representing a minor engaged in a sexually explicit conduct;

Computer system: any isolated or non-isolated device or group of interconnected devices that all or in part carries out automatic processing of data pursuant to a programme.

Information Technology and Communication (ITC): technologies used to gather, store, use and send information, including technologies that involve the use of computers or any communication system, including any telecommunication system.

Article 2 Objective

The objective of this Directive is to adapt the substantive criminal law and the criminal procedure of ECOWAS Member States to address the cybercrime phenomenon.

Article 3 Scope

This Directive shall be applicable to all cyber crime-related offences within the ECOWAS sub-region as well as to all criminal offence whose detection shall require electronic evidence.

CHAPTER 11

OFFENCES SPECIFICALLY RELATED TO INFORMATION AND COMMUNICATION TECHNOLOGIES

For the purposes of this Directive, the following shall constitute offences:

Article 4 Fraudulent access to computer systems

Fraudulent access to computer systems is the act by which a person fraudulently accesses or attempts to access the whole or part of a computer system.

Article 5 Fraudulently remaining in a computer system

Fraudulently remaining in a computer system is the act by which a person fraudulently remains or attempts to remain within the whole or part of a computer system.

Article 6 Interfering with the operation of a computer system

Interfering with the operation of a computer system is the act by which a person impedes, alters or attempts to impede or alter the functioning of a computer system.

Article 7 Fraudulent input of data in a computer system

Fraudulent input of data in a computer system is the act by which a person fraudulently inputs or attempts to input data into a computer system.

Article 8 Fraudulent interception of computer data

Fraudulent interception of computer data is the act by which a person fraudulently intercepts or attempts to intercept computer data during their non-public transmission to, from or within a computer system using technological means.

Article 9 Fraudulent modification of computer data

Fraudulent modification of computer data is the act by which a person fraudulently damages or attempts to damage, delete or attempts to delete, worsen or attempting to worsen, alter or attempts to alter, modify or attempt to modify computer data.

Article 10 Computer data forgery

Computer data forgery is the act by which a person produces or manufactures a set of digital data through fraudulent input, deletion or suppression of computer data stored, processed or transmitted by a computer system, resulting in counterfeit data, with the intent that it be considered or used for legitimate purposes as if it were genuine.

Article 11 Obtaining benefit from Computer related fraud

Obtaining benefit from Computer related fraud is the act of obtaining fraudulently for oneself or for another person material or economic benefit through the input, alteration, deletion or suppression of computer data or through any other form of interference with the functioning of a computer system.

Article 12 Fraudulent manipulation of personal data

Fraudulent manipulation of personal data is the act by which a person, even through negligence, processes personal data or causes personal data to be processed without having complied with the prerequisite conditions stipulated by the relevant law on personal data provided for in each Member State.

Article 13 Use of forged data

Use of forged data is the act by which a person knowingly uses forged data.

Article 14 Obtaining equipment to commit an offence

Obtaining equipment to commit an offence is the act by which a person knowingly without any legitimate reason produces, sells, imports, possesses, distributes, offers, transfers or makes available equipment, computer programmes, or any device or data, any password, -access code or similar computer data by which they

commit any offence as stipulated in this Directive.

Article 15 Participation in an association or agreement to commit computer offences

Participation in an association or agreement to commit *computer* offences is the act by which a person participates in an association that is formed or an agreement that is established for the purpose of preparing or committing one or several of the offences described in this Directive.

Article 16 Production of child pornography or pornographic representation

Production of child pornography or pornographic representation is the act by which a person produces, records, offers or makes available, distributes or transmits child pornography or pornographic representation through a computer system.

Article 17 Import or export of child pornography or pornographic representation

Import or export of child pornography or pornographic representation is the act by which a person procures for oneself or for another person, imports or causes to be imported, exports or

causes to be exported, child pornography through a computer system.

Article 18 Possession of child pornography or pornographic representation

Possession of child pornography or pornographic representation is the act by which a person possesses child pornography or pornographic representation through a computer system or through any other computer data storage medium.

Article 19 Facilitation of access of minors to pornography, documents, sound or pornographic representation

Facilitation of access of minors to pornography, documents, sound or pornographic representation is the act by which a person facilitates access of a minor to pornographic pictures, sounds or representation.

Article 20 Possession of racist or xenophobic written documents or pictures through a computer system

Possession of racist or xenophobic written documents or pictures through a computer system is the act by which a person creates, downloads, disseminates, or makes available in whatever form, written documents, messages, photographs, drawings or any other depictions of racist and xenophobic ideas and theories by means of a computer system.

Article 21 Threat through a computer system

Threat through a computer system is any threat through a computer system to commit a criminal offence against a person by reason of his affiliation to a group that is characterised by race, colour, ancestry, ascendants, religion, national or ethnic origin, to the extent that this affiliation serves as a pretext for such a threat to that person or a group of persons that is distinguished by one of the foregoing characteristics.

Article 22 Abuse through a computer system

Abuse through a computer system is any abuse to a person through a computer system by reason of his belonging to a group that is characterised by race, colour, ancestry, ascendants, religion, national or ethnic origin, to the extent that this affiliation serves as a pretext for such an abuse to the person or a group of persons that is distinguished by the foregoing characteristics.

Article 23 Denying or justifying acts or crimes against humanity by means of a computer system

Denying or justifying acts or crimes against humanity by means of a computer system is any intentional act to deny, approve or justify established acts of genocide or crimes against humanity by means of a computer system.

CHAPTER III

INCORPORATING TRADITIONAL OFFENCES INTO INFORMATION AND COMMUNICATION TECHNOLOGY OFFENCES

Article 24 Aggravating Circumstances of Common Law Offences

Under this Directive, the use of ICTs to commit common law offences such as theft, fraud, possession of stolen goods, breach of trust, extortion, terrorism, and money laundering or organised crimes shall constitute a higher degree of offence than the common law offences.

Article 25 Violations of computer data, software and programme

Under this Directive, theft, fraud, possession of stolen goods, breach of trust, extortion, acts of terrorism, and counterfeiting

relating to computer data, software and programme shall constitute an offence.

Article 26 Media offence committed through electronic means of communication

Media offences committed through electronic means of communication under this Directive shall be subjected to the provisions relating to media offences which are applicable in Member States.

Article 27 Liability of Corporate Bodies other than Public Entities

Any corporate body, excluding the State, local authorities and public establishments, shall be held liable for any of the offences described in this Directive that are committed for their benefit by their representatives. Such liability shall not exclude the liability of individuals who commit such acts or abet the commission of such acts.

CHAPTER IV

SANCTIONS

Article 28 Major penalties

- 1) The offences stipulated under this Directive shall be punishable under the criminal Court of Member States. Sanctions shall be proportionate and dissuasive.
- 2) Any corporate body found liable under this Directive shall be punishable by proportionate and dissuasive sentences, including criminal and civil penalties.

Article 29 Supplementary Penalties

1. In the event of conviction for an offence committed through an electronic communication medium, the relevant jurisdiction may decree supplementary sanctions.
2. In the event of conviction, the court may decide that materials, equipment, instruments, computer programmes or data, as well as proceeds from an offence and belonging to the convicted person be confiscated.
3. Conviction decisions shall be published in the National Gazette of Member States and in an electronic medium at the expense of the convict.

CHAPTER V:

RULES OF PROCEDURE

Article 30 Search or access to a computer system

1. The national competent authority may carry out searches or effect seizures or have access to any computer system in order to establish the truth.

2. However, where seizure of the electronic medium is undesirable, the data required to understand it shall be copied on a computer data storage medium and sealed.

Article 31 Expedited preservation of data

Where the exigencies of information so require, and where there is reason to believe that computerized data recorded in a computer system can be lost, the national competent authority shall order any individual to keep and protect in secret the integrity of data in his possession or under his control within a time line set by a Member State.

Article 32 Method of Proof

Electronic evidence shall be accepted as proof to establish an offence provided the person from whom they emanate can be identified and that they are kept in such conditions as to guarantee their integrity.

Article 33 .Judicial Cooperation

1. Where Member States are informed by another Member State of the alleged commission of an offence as defined in this Directive, such Member States shall cooperate in the search for and establishment of that offence, as well as in the collection of evidence pertaining to the offence.
2. Such cooperation shall be carried out in line with relevant international instruments and mechanisms on international cooperation in criminal matters.

CHAPTER VII:

FINAL PROVISIONS

Article 34 Publication

This Directive shall be published by the Commission in the Community Official Journal within thirty (30) days of the date of signature by the

Chairman of the Council of Ministers. It shall equally be published by each Member State in its national Gazette thirty (30) days after notification by the Commission.

Article 35 Implementation

1. Member States shall adopt the necessary legislative, regulatory and administrative measures in order to comply with this Directive not later than 1st January 2014.
2. The measures referred to in Paragraph 1 of this Article should make reference to this Directive or shall be accompanied by such reference upon their official publication.
3. Member States shall inform the ECOWAS Commission of the measures they will adopt to comply with this Directive.
4. Member States shall notify the President of the Commission of the difficulties they encounter in implementing this Directive. The President of the Commission shall report such difficulties at the next session of the Council of Ministers which shall, in turn, take the appropriate measures to ensure the effective implementation of this Directive.

DONE AT ABUJA, THIS 19TH DAY OF AUGUST 2011



.....
H.E. OLUGBENGA ASHIRU

CHAIRMAN

FOR COUNCIL



**DECISION C/AHSG.1/09/11 ON MEASURES TO
RESPOND TO THE SECURITY SITUATION IN COTE
D'IVOIRE AND LIBERIA AND ALONG THE BORDER
CORRIDOR BETWEEN THE TWO MEMBER STATES**

**THE CHAIRMAN OF THE AUTHORITY OF HEADS OF
STATE AND GOVERNMENT,**

MINDFUL of Articles 7, 8 and 9 of the ECOWAS Treaty as amended establishing the Authority of Heads of State and Government and defining its composition and functions;

MINDFUL of new Article 9 of the ECOWAS Treaty as amended by Article 1 of the Supplementary Act A/SA.3/01/10 on the Legal Regime of Acts of the Community that prescribes that the Authority shall adopt decisions that are directed to whom they are meant under the said decisions;

MINDFUL of Decision A/DEC.2/07/10 of 2 July 2010 adopting the Rules and Procedures of the Authority of heads of State and Government;

MINDFUL of Article 13 paragraph 3 of the Rules and Procedure of the Authority of Heads of State and Government prescribing in Article 13 Paragraph 3 that, in-between two sessions, the Chairman shall exercise the powers of the Authority and act on its behalf;



RECALLING that at the Thirty-Ninth Ordinary Session of Authority held in Abuja on 23 and 24 March 2011, the Heads of State and Government renewed the tenure of the Federal Republic of Nigeria as Chair of the ECOWAS Authority of Heads of State and Government until 31 December 2011;

CONSIDERING that the border zone between Côte d'Ivoire and Liberia is teeming with mercenaries and armed bandits amidst the unchecked flow of small arms and light weapons;

CONSIDERING that the said arms and weapons are used to terrorize the civilian population and for cross-border criminality;

NOTING that more than one million citizens of both Côte d'Ivoire and Liberia have been internally displaced by acts of violence, revenge killing and intimidation in their own countries;

NOTING also that as a result of protracted conflicts in Côte d'Ivoire and Liberia, thousands of community citizens were forced to flee across borders to seek refuge in neighboring countries;

AWARE that ECOWAS is working closely with the United Nations High Commission for Refugees (UNHCR) to identify new refugees and Internal Displaced Persons (IDPs) in all



Member States involved, with the view to managing their serious humanitarian situation;

CONCERNED about the huge humanitarian challenge to be faced by the region in feeding more than one million people daily, until normalcy is restored in the above mentioned Member States;

ENCOURAGED by the deliberate policy adopted by Cote d'Ivoire and Liberia to reconcile political and ethnic opponents with a view to achieving unity of purpose and action in both countries;

CONSCIOUS of the fact that Cote d'Ivoire and Liberia have already taken steps to embark on national reconciliation processes, including the setting up of Truth and Reconciliation Commissions (TRC), to examine the violent past with a view to reconciling the people;

CONSCIOUS also that Cote d'Ivoire and Liberia need tremendous assistance from ECOWAS and external partners to supplement their effort in dealing with the after effects of the decisions emanating from the findings of the TRC;

DESIROUS to respond to the grave security situation that has developed in Côte d'Ivoire and Liberia and to assist in stabilizing the border zone between these Member States;



ON THE RECOMMENDATION of the ECOWAS Mini-Summit of Head of States and Government held in Abuja on the 10th September 2011

HEREBY DECIDES

Article 1

The ECOWAS Commission shall work in close collaboration with the Security Forces in Côte d'Ivoire and Liberia in order to provide additional support to the efforts of the United Nations (UN).

Article 2

The ECOWAS Commission shall consider the possibility of developing new security alternatives with Côte d'Ivoire and Liberia within the framework of the ECOWAS Mechanism.

Article 3

The ECOWAS Commission shall solicit the assistance of the United Nations in order to achieve the following:

1. greater United Nations security efforts in the region as well as greater cooperation between ECOWAS and the United Nations;



2. additional technical assistance for the peace-keeping missions for the intensification of a joint UNOCI-UNMIL monitoring and control of the common border zone between Cote D'Ivoire and Liberia;
3. a more secure environment which is conducive for the conduct of free, fair and transparent elections in Liberia and for the unhindered movement of people along the border areas of the two countries.

Article 4

1. The President of the Commission shall appoint a Special Envoy in Liberia who shall act as liaison between the ECOWAS Commission and that Country and in particular assist with the monitoring of the forthcoming elections in Liberia.
2. The President of the Commission shall also engage UNOWA in order to undertake a joint ECOWAS - UNOWA mission to Liberia to interact with all stakeholders in order to sensitize them on the need for their cooperation for the successful holding of the elections in Liberia.



Article 5

The ECOWAS Commission shall oversee the effective implementation of the ECOWAS convention on small arms and light weapons (SALW) in particular within the Mano River Basin, with a view to controlling the acquisition, proliferation and misuse of the weapons.

Article 6

1. The President of the Commission shall intensify ECOWAS efforts at mobilizing and delivering humanitarian assistance for the refugees and IDPs along the common borders between Côte d'Ivoire and Liberia.
2. The President of the "ECOWAS Commission shall ensure more effective collaboration with the UN agencies in facilitating the return and settlement of refugees and IDPs of the two Member States.

Article 7

1. The ECOWAS Commission shall work closely with the Government of Côte d'Ivoire in its efforts to achieve justice and national reconciliation.



2. The Commission shall assist Côte d'Ivoire in the identification and provision of experts, consultants and other technical/financial support.

Article 8

This Decision shall be published by the ECOWAS Commission in the Official Journal of the Community within thirty (30) days of its signature by the Chairman. It shall also be published by each Member State in its Official Gazette within the (30) thirty-day timeframe after notification by the Commission thereof.

DONE AT ABUJA, THIS 10TH DAY OF SEPTEMBER 2011

H.E. GOODLUCK EBELE JONATHAN (GCFR)

FOR THE AUTHORITY,

THE CHAIRMAN



SIXTY-SIXTH ORDINARY SESSION OF THE COUNCIL OF MINISTERS

Abuja 17 - 19 August 2011

RECOMMENDATION C/REC.1/08/11 RELATING TO THE HARMONISATION OF STANDARDS AND PROCEDURES FOR THE CONTROL OF DIMENSION, WEIGHT AND AXLE LOAD OF GOODS VEHICLE WITHIN MEMBER STATES OF THE ECONOMIC COMMUNITY OF WEST AFRICAN STATES

THE COUNCIL OF MINISTERS,

MINDFUL of Articles 10, 11 and 12 of the ECOWAS Treaty as amended, establishing the Council of Ministers and defining its composition and functions;

MINDFUL of Article 32 of the said Treaty which provides for the adoption of common transport and communication policies, laws and Regulations as a means of ensuring harmonious integration of the physical infrastructure of Member States and the promotion and facilitation of movement of persons, goods and services within the Community;

MINDFUL of Decision AIDEC. 2/5/81 relating to the harmonization of highway legislations in the Community;

MINDFUL of the ECOWAS Convention No. AIP2/5/82 of 29 May 1982 Relating to Inter-State Road Transportation between ECOWAS Member States providing amongst other issues, the tonnage for axle load and other dimensions for vehicles;

MINDFUL of Resolution C/RES.5/5/90 of 27 May 1990 urging Member States to introduce Weighbridge and axle scales as a means of effectively monitoring the tonnage transported as well as axle load;

MINDFUL OF Decision C/DEC/7/7/91 of 3 July 1991 Relating to the Road Traffic Regulations based on 11.5 Axle Load to protect Road Infrastructures and Road Transport Vehicles, especially the annex thereof, which provides for eventual harmonization of the sanctions imposed on anyone in breach of the said Regulations;

MINDFUL OF Decision AIDEC. 2/8/94 relating to the Community Programme on Road Safety and Accident prevention in ECOWAS Member States;

MINDFUL OF Decision AIDEC.6/7/96 of 27th July 1996 establishing standards for the design of Community roads;

CONSIDERING Regulation14/2005/CM/UEMOA of 16 December 2005 on Harmonization of the Control of the Dimension, Weight and Axle Load of Heavy Duty Goods Transport Vehicles in UEMOA Member States;

CONSIDERING Resolution No. 2 of the Meeting of ECOWAS Transport Ministers on Implementation of the Regulation on the Control of Vehicle Axle Load, held in Yamoussoukro in Cote d'Ivoire on 5 June 2009;

CONSIDERING the Road map of March 2010 relating to the abolition of the surcharge adopted by the Ministers responsible for Infrastructures and Transport in the UEMOA Member States and in Ghana;

DETERMINED to effectively preserve the road heritage of Member States;

DESIROUS of harmonizing the standards and procedures for the control of the load, dimension limits and axle load of vehicles amongst Member States of the Community;

ON THE RECOMMENDATION of the meeting of Ministers of Infrastructure and Transport held in Accra, on the 1st April, 2011;

HAVING obtained the opinion of the Community Parliament

RECOMMEND to the Authority of Heads of State and Government to adopt the Draft Supplementary Act relating to the Harmonisation of Standards and Procedures for the Control of Dimensions, Weight and Axle Load of Goods Vehicle within Member States of the Economic Community of West African States (ECQWAS).

DONE AT ABUJA, THIS 19TH DAY OF AUGUST 2011

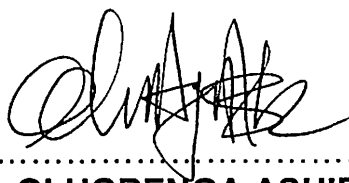

.....
H.E. OLUGBENGA ASHIRU

CHAIRMAN

FOR COUNCIL

Fortieth Ordinary Session of the Authority of the Heads of State and Government

Abuja, ... 2011

Draft

SUPPLEMENTARY *ACT/SP.1/08/11* RELATING TO THE HARMONIZATION OF STANDARDS AND PROCEDURES FOR THE CONTROL OF DIMENSIONS, WEIGHT AND AXLE LOAD OF GOODS VEHICLE WITHIN MEMBER STATES OF THE ECONOMIC COMMUNITY OF WEST AFRICAN STATES

MINDFUL of Articles 7, 8 and 9 of the ECOWAS Treaty as amended, establishing the Authority of Heads of State and Government and defining its composition and functions;

MINDFUL of Article 32 of the said Treaty which provides for the adoption of common transport and communication policies laws and Regulations as a means of ensuring harmonious integration of the physical infrastructure of Member States and the promotion and facilitation of movement of persons, goods and services within the Community;

MINDFUL of Decision AIDEC. 2/5/81 relating to the harmonization of highway legislations in the Community;

MINDFUL of the ECOWAS Convention No. AIP2/5/82 of 29 May 1982 Relating to Inter-State Road Transportation between ECOWAS Member States providing amongst other issues, the tonnage for axle load and other dimensions for vehicles;

MINDFUL of Resolution C/RES.5/5/90 of 27 May 1990 urging Member States to introduce Weighbridge and axle scales as a means of effectively monitoring the tonnage transported as well as axle load;

MINDFUL of Decision C/DEC.7/7/91 of 3 July 1991 Relating to the Road Traffic Regulations based on 11.5 Axle Load to protect Road Infrastructures and Road Transport Vehicles, especially the annex thereof, which provides for eventual harmonization of the sanctions imposed on anyone in breach of the said Regulations;

MINDFUL of Decision AIDEC. 2/8/94 relating to the Community Programme on Road Safety and Accident prevention in ECOWAS Member States;

MINDFUL of Decision AIDEC.6/7/96 of 27th July 1996 establishing standards for the design of Community roads;

CONSIDERING Regulation14/2005/CM/UEMOA of 16 December 2005 on Harmonization of the Control of Dimension, Weight and Axle Load of Heavy Duty Goods Transport Vehicles in UEMOA Member States;

CONSIDERING Resolution No. 2 of the Meeting of ECOWAS Transport Ministers on Implementation of the Regulation on the Control of Vehicle Axle Load, held in Yamoussoukro in Cote d'Ivoire on 5 June 2009;

CONSIDERING the March 2010 road map forbidding transport overloading adopted by the UEMOA Ministers in Charge of Infrastructure and Transport in Ghana.

DETERMINED to effectively preserve the road heritage of Member States;

DESIROUS of the harmonization of standards, and procedures for the control of load, dimension limits, and axle load of vehicles amongst Member States of the Community;

ON THE RECOMMENDATION of meeting of Ministers of Road Transport and Infrastructure for the Review and adoption of the ECOWAS Axle Load and the PPDU Regulations which was held in Accra on 1st April 2011 ;

HAVING OBTAINED the opinion of the Community Parliament;

HAVE AGREED AS FOLLOWS:

CHAPTER I: DEFINITIONS, OBJECTIVE AND SCOPE OF APPLICATION

Article 1 Definitions

The technical terms used in this Supplementary Act with regard to vehicle type, vehicle axle, vehicle dimensions and weight and to goods transport activity, are defined in Annex 1 attached to this Supplementary Act.

Article 2 Objective and scope of application

1. The objective of this Supplementary Act is to harmonize amongst ECOWAS Member States, the standards the control of dimension, weight and axle load of heavy duty goods transport vehicles, and the sanctions imposed for non-compliance with these standards.
2. This Supplementary Act complements and amends all relevant ECOWAS texts, particularly Convention *A1P2/5/82* of 29 May 1982, Decision *C/DEC/717/9* of 13 July 1991 and Council of Ministers Resolution *5/5/90* of 27 May 1990.
3. Annexes 1 and, 2 to this Supplementary Act form an integral part thereof. The weight and dimension limits set forth herein, deriving from the aforementioned previous texts, shall constitute the load standards for heavy-duty goods transport vehicles plying public roads in ECOWAS Member States.

CHAPTER 11: LIMITS TO THE DIMENSIONS, WEIGHT AND AXLE LOAD OF HEAVY DUTY GOODS TRANSPORT VEHICLES

Article 3 Limits to heavy duty vehicle dimensions

The external dimensions of any vehicle or assembly of vehicles plying the road network of ECOWAS Member States shall not exceed the authorized maximum dimensions set forth in Annex 2 of this Supplementary Act.

Article 4 Limits of axle load

In accordance with Article 4 of Convention *AIP2/5/82* of the Authority of Heads of State and Government of ECOWAS and Article 1 of the Council of Ministers Decision *C/DEC/717/91*, transport vehicle traffic on roads networks of ECOWAS Member States shall be permissible subject to a maximum axle load of 11.5 tons for single load-carrying axles.

The Authorized Maximum Axle Loads (AMAL) for the various types of axle are listed in Annex 2 of this Supplementary Act.

Article 5 Limits to laden weight

For each type of vehicle or assembly of vehicles, the authorized Total Laden Weight (ATLW) or the authorized Total Transported Weight (ATTW) shall be defined in conformity with Annex 2 of this Regulation.

Article 6 Exceptions for exceptional transport

In conformity with Article 7 of the Convention *AIP2/5/82* and as provided in the annex to Decision *717/91* Special transport vehicles or exceptional convoys of vehicles that are not compliant with the standards defined in Article 3, 4 and 5 of this Supplementary Act shall, while transiting in each Member State, be subject to prior authorization for exceptional transport issued by the competent authorities. The beneficiary of such authorization shall hold the same in possession in the course of the journey.

CHAPTER III: MEASURES TO IMPLEMENT AND CONTROL THE STANDARDS

Article 7 Load and Dimensions Inspection Certificate

1. Pursuant to implementation of this Supplementary Act, each Member State shall formulate and incorporate in its official transport document (traffic document or road consignment note) a note in the certificate attesting that a vehicle's weight and dimensions have been duly checked. The total laden weight and the overall axle system load of the concerned vehicle shall be clearly mentioned, and there shall be express indication as to the vehicle's conformity with the dimension standards.
2. With respect to exceptional transport, the authorization for exceptional transport set forth in Article 6 shall apply.

Article 8 Technical inspection of heavy-duty vehicles

1. Prior to registration and entry into service, every vehicle shall be subject to technical inspection by the competent administration in the Member State. The dimension, weight and axle type specifications (with the nomenclature used in this Supplementary Act) shall be clearly inscribed in two plates:
 - a) A tare plate clearly displaying:
 - i) The unladen weight (UW) - at full tank;
 - ii) Authorized total laden weight (ATLW) of the vehicle; and
 - iii) Type of the vehicle axle.
 - b) A dimensions plate displaying the dimension specifications of the vehicle.
2. The two plates shall be affixed to the vehicle.
3. Technical inspection shall be compulsory upon a vehicle's entry into circulation after an accident or significant transformation thereto. The vehicle owner shall request for this inspection from the Competent Authority.

4. During the periodic vehicle inspection stipulated in Article 10 of Convention A1P2/5/82, the dimension and weight specifications inscribed on the plates shall be checked.
5. As regards an assembly of vehicles, the provisions of this Article shall apply to each component of the fleet.

Article 9 Obligatory Inspection of Equipment and Devices

A. For Member States

- 1) Pursuant Resolution C/RES.5/5/90 and for the purposes of effective inspection, Member States shall install or cause to be installed equipment for control of the set limits to vehicle load and dimensions. The equipment in question are essentially weighbridges, weighing scales and dimension gauges.
- 2) The said equipment shall be installed in the form of fixed posts along inter-State road corridors, at the beginning and at the end of such corridors, and at the borders where the equipment can be used by the relevant authority of neighbouring Member States in line with the concept of adjoining check points. In addition, mobile weighing scales shall be used for unscheduled inspections.
- 3) It shall be the responsibility of the State to ensure that the inspection equipment is installed at the exit of urban agglomerations which generate annual road freight for heavy-duty vehicles of over two hundred thousand (200,000) ton
- 4) The equipment forming part of the installations referred to under paragraph 3 of this article shall be inspected frequently each year and recalibrated by a metrology service recognized or certified by the State.

B. For platforms that generate heavy traffic

- 1) Operators of port and airport transit platforms, logistics platforms, rail-road inter-modal platforms, warehousing and storage facilities, as well as industrial and/or mining institutions which generate heavy-duty vehicle goods traffic of over two hundred thousand (200,000) tones annually, shall equip their platforms or facilities with an installation having the specialized facilities required for inspection of the dimensions, weight and axle load of heavy-duty cargo transport vehicles loading in their respective domains.
- 2) The operator shall be required to obtain a certificate of compliance from the national administration in charge of transport
- 3) Member States shall ensure the implementation of these provisions by those in charge of platforms.

CHAPITE IV: INSPECTION OF HEAVY-DUTY VEHICLES DIMENSION, WEIGHT AND AXLE LOAD ALONG ROAD CORRIDORS

Article 10 Responsibilities of loading platforms prior to departure of a laden truck

1. Operators of the platforms and facilities mentioned in Article 9(8) of the Supplementary Act shall ensure and certify in their inspection installations by their respective services or by any other service provider operating on behalf of their services, that the standards regarding the dimensions, weight and axle load limits for heavy-duty vehicles loaded in the said platforms and/or facilities have been complied with. The services or service providers in question shall accordingly issue an inspection certificate as provided for in Article 7 of this Supplementary Act.
2. Such inspection shall be conducted at the expense of the vehicle operator. The inspection certificate where so issued shall

be kept aboard the vehicle for presentation on demand during road inspections.

3. The vehicle may not leave the premises of the platform or facility with its cargo and re-embark on the journey unless it is in compliance with the standards set forth by this Supplementary Act, or the vehicle operator has an authorization for exceptional transport. Prohibition from leaving the platform/facility premises for non-compliance shall be the responsibility of the owners of the said platforms or facilities.
4. Every urban agglomeration generating outgoing road cargo traffic for heavy-duty vehicles of over two hundred thousand (200,000) tones annually shall offer every heavy-duty vehicle transporter the opportunity to ensure that his/her laden vehicle conforms with the dimensions, weight and axle load standards set for such vehicles. The offer shall be extended by putting in place an appropriate technical facility operated by or on behalf of the services of the administration or by a private operator accredited by the road administration.

Article 11 Responsibilities of vehicle operators prior to departure of laden trucks

The vehicle operator or his/her representative shall ensure that, at the point of loading and of departure that the said vehicle is compliant with the dimensions, weight and axle load standards set for the vehicle. The vehicle operator shall be held responsible, unless proved otherwise, for non-compliance with the said standards on public roads.

Article 12 Inspection at fixed posts

1. Each fixed inspection post shall, at the minimum, be equipped with vehicle weighing facility for inspection of axle load and total vehicle weight, as well as a facility for measuring vehicle dimensions. The fixed inspection posts shall have secured cargo warehousing facilities and secured parking spaces for immobilized vehicles in order to facilitate implementation of the

sanctions set forth in Articles 16 and 17 of the Supplementary Act.

2. The number of inspection posts along any Community transit corridor in a Member State may not exceed three [3] in each traffic direction, including the posts in the precincts of the aforementioned sources of heavy traffic where such posts are located on the border corridors and posts. The inspection posts situated on Community transit corridor feeder roads are not subject to this limit..
3. Weighing-toll posts shall not be included in the number of inspection fixed posts mentioned in paragraph 2 of this Article. Transit transport vehicles with the stickers provided for in the regional road inspection plan shall not be subject to the weighing formalities at the said weighing-toll posts.

Article 13 Inspection by mobile brigade

1. In addition to establishing the system of inspection fixed posts stipulated in Article 12, the road inspection system in each Member State shall be provided with standardized mobile equipments.
2. Mobile road inspection shall be conducted without prior notice. It is primarily intended to control offences and fraud committed on crossing inspection fixed posts. It is also aimed at controlling the vehicles not intercepted at an inspection fixed post. Mobile road inspection shall entail only the verification of compliance with the standards stipulated in this Supplementary.
3. Mobile road inspection along any Community transit corridor in a Member State may be operated only within the limits of a total of three consecutive inspection points, in each traffic direction along the corridor, fixed posts and mobile inspection posts inclusive, counted in the same way as in Article 12 above.

4. Inspection at mobile check points shall be conducted at random and through sampling of units of traffic plying the road without forming a queue. No other vehicle in circulation shall be intercepted during a vehicle inspection operation; and no vehicle shall be kept waiting for the purpose of inspection.
5. A transit transport vehicle may be inspected right through the journey, for every transit corridor in a Member State.

Article 14 Content of road inspection and mode of management

1. Apart from the inspection of vehicle and driver's particulars, fixed and mobile posts inspection shall entail verification of conformity with the dimension and load standards set forth in Articles 3, 4 and 5 of this Supplementary Act.
2. In each Member State, the road inspection system defined in Articles 12 and 13 of this Supplementary Act and the mode of management and operation thereof fall under the purview of the Member State, with the exception of the adjoined inspection posts at the border of two Member States, which shall be governed by a special regime.
3. The inspection posts juxtaposed at the border of two Member States shall be located on common land entry-exit platforms. Legal provisions defining the status of such platforms shall be put in place by the ECOWAS Commission.

CHAPTER V: SANCTIONS FOR NON-COMPLIANCE WITH THE DIMENSIONS, WEIGHT AND AXLE LOAD LIMITS

Article 15 Content of the Sanctions

1. A breach of the standards and non-compliance with the responsibilities laid down in this Supplementary Act shall attract sanctions set forth in Articles 16 to 24 hereunder.

2. In general terms, in the event of non-conformity with dimensions and weight limits, the sanctions imposed shall comprise:
 - a) Corrective measures as well as measures imposed to oblige compliance with the relevant standards (weight and load shedding) at the expense of the offender with a view to eliminating the impact of the offence on the rest of the journey;
 - b) Dissuasive fine determined in accordance with seriousness of the offence to be defined in the manner provided under Article 18 of this Supplementary Act.
3. The level of fine for overloading shall be determined in such a way that the amount applicable shall be at least equal to the income expected by a public transporter on the transportation of the cargo weight that constituted the overload. In this regard, account shall be taken of the average cost of heavy-duty transportation of a kilometer tone and the average transportation distances in respect of national and inter-State transport.

Article 16 Compulsory overload shedding and correction of dimensions

1. The operator of a vehicle found to be non-compliant with the loading standards stipulated in this Supplementary Act shall have the obligation to conform with the Act prior to putting the vehicle back in circulation.
2. Payment of the fine incurred notwithstanding, the vehicle operator shall be required to cause the excess load to be discharged and/or re-order the vehicle load with a view to bringing the vehicle load and dimensions back to permissible limits.
3. The operations to load and re-load off-loaded cargo shall be the responsibility of the vehicle operator who shall exclusively bear the cost.

4. In the case of a sealed vehicle or a transit transport vehicle under ISRT regime, the operations referred to in paragraph 3 of this Article shall be conducted under customs oversight.
5. Where a non-compliant vehicle is intercepted by mobile inspection, such vehicle shall be immediately escorted to the nearest inspection fixed post.

Article 17 Immobilization of vehicle and compulsory cargo trans-shipment

1. Where an inspected vehicle is found to be in breach of the dimension standards set forth in Article 3 of this Supplementary Act and the cause of the non-compliance is not due to loading but solely to the technical specifications of the vehicle, the vehicle operator shall be required to transfer its cargo to another vehicle that is compliant with the dimension standards.
2. The defaulting vehicle shall be immobilized at the inspection post under the responsibility of the post operator pending the arrival of the inspection post vehicle to which the cargo is to be trans-shipped. The trans-shipment shall be Effected at the inspection post by the vehicle operator under the supervision of the post operator.
3. The owner of the non-compliant vehicle shall be sanctioned with immobilization of the said vehicle at a location indicated by him/her, until the vehicle is brought to conformity.

Article 18 Fine

1. 1 The amounts for fines attached to sanctions prescribed under chapter 5 of this Supplementary Act shall be defined in a Regulation to be adopted by the Council of Ministers on the recommendation of the sector Ministers. All such fines shall be calculated in the United States dollars but paid in the appropriate local currency. The amounts shall be reviewed periodically by the Council of Ministers on the advice of the sector Ministers.

2. In the absence of Dimension and Tare Plates

Any owner of a vehicle without the dimension and tare plates stipulated in Article 8 of this Supplementary Act shall be sanctioned with a fine.

3. For lack of inspection certificate

1. Any international transport vehicle without inspection certificate in its set of travel documents as prescribed in Article 7 of this Supplementary Act, or without the authorization for exceptional transport in lieu of the certificate, shall be sanctioned with a fine in exchange for the eventual issuance of a certificate of compliance in lieu of inspection certificate, to complete the rest of the journey.
2. In the event of a mobile inspection, the defaulting vehicle shall be escorted to the nearest stationed inspection post for the purpose of issuance of the requisite certificate after verification of compliance with all the prescribed limits.

4. For breach of dimension standards

1. Any breach of the dimension standards resulting exclusively from vehicle load shall attract a fine at the expense of the operator of the vehicle.
2. Any breach of the dimension standards due exclusively to the specifications of the vehicle shall be punished with a fine at the expense of the owner of the vehicle and immobilization shall be imposed in accordance with the provisions of Article 17 of the Supplementary Act.

5. For exceeding the total travelling weight of the vehicle

Any overload beyond the regulated total laden weight of a vehicle or assembly of vehicles with regard to national and inter-state transport shall attract fines to be determined in the manner provided for under Article 18 {1} of this Supplementary Act. A five percent (5%) allowance on the total laden weight is however made to take into account the margin of error of the weighing facility.

6. For axle overload

1. Any excess of axle load for national and international transport in violation of the standards set forth in Article 4 of this Supplementary Act shall attract fines calculated per ton overload in respect of the axle accounting for the highest overload amongst all the axles of the vehicle.:
2. Where the two kinds of overload, namely, weight overload and axle overload, have been observed in respect of the same road transport vehicle, the penalty applicable shall be the highest.

Article 19 Special case of transportation of hydrocarbons, explosives and certain dangerous cargo

1. In special cases where the cargo transported by the weight or dimension non-compliant vehicle is composed of hydrocarbons, explosives and certain dangerous cargo which cannot be manipulated and/or stored in inspection fixed post facility for security reasons, the vehicle shall immediately be escorted to its loading point, its journey starting point, the off load point or destination, depending on the point with the shortest distance between the two destinations, that is, from the inspection point where the offence was observed, and the fixed or mobile post.
2. The fine applicable shall be double the fine set for similar offence in case of ordinary cargo transport.
3. With respect to transit transport, escorting the vehicle back to the loading point shall be supervised by the customs.

Article 20 Increased fine for repeated breach

1. Repeated breaches of the standards in respect of both dimension and load shall attract increased fines at rates determined in a Council Regulation as stated in Article 18 {1} of this Supplementary Act.
2. For the purpose of implementing the provisions of subparagraph 1 of this Article, annual computation of offences shall

be carried out in respect of the offences committed in the territory of the same State and detected at the control system. Such computation shall be managed by the operator of the inspection system.

3. In the special case of adjoining inspection posts at the borders, the provisions of Paragraph 1 of this Article above shall be applied on the basis of computation of offences detected at the same joint border post.

Article 21 Fines for proven offences at inspection fixed posts

During unscheduled mobile inspection, any offence or offences involving a vehicle at the last inspection of dimension, weight and axle load at a fixed post shall attract the requisite fine. This sanction shall be additional to the other sanctions defined in earlier Articles.

Article 22 Obligation to implement sanctions

A defaulting vehicle may not be authorized to leave the inspection fixed post or the destination designated for the vehicles mentioned in Articles 17 and 19 of this Supplementary Act, unless the vehicle operator produces proof that the requirements laid down under the sanctions have been met, and that the fine and other sanctions imposed have been cleared at the inspection fixed posts holding and processing the dossier regarding the offense.

Article 23 Fine imposed for deliberate refusal to pass through the weigh-bridge and axle weighing scales

Any deliberate refusal by the driver of a vehicle to pass through the weigh bridge or axle weighing scale shall be sanctioned in addition to such other coercive measures as may be applicable. Such sanction shall be imposed on the vehicle operator who may institute a claim against the driver.

Article 24 Sanction against platforms and facilities generating
Out-going road traffic of over 200,000 tones

1. Any corporate body operating a platform or facility of the category defined in Article 9 (8) of this Supplementary Act without the compulsory inspection facilities mentioned in the said Article, shall attract a fine. This fine becomes applicable at the expiration of two years deadline following the formal notification of the obligation to be compliant, issued by the national administration in charge of transport where the corporate body in question fails to meet the obligation.
2. Any corporate body referred to under Article 9 (8) that has conformed with the obligations in terms of the inspection equipment and facilities mentioned in the same Article but is in breach of the obligations regarding vehicle inspection and prohibition from leaving the inspection post defined in Article 10 of this Supplementary Act, shall be sanctioned with a fine per any vehicle loaded in the precincts of the defaulting platform or facility.

CHAPTER VI: GENERAL AND FINAL PROVISIONS

Article 25 Adaption and/or amendment of technical standards of
vehicles and sanctions

1. The technical standards for heavy duty goods transporting vehicles plying public highways within the limits of dimension of heavy vehicles, axle load, laden load shall be adapted periodically in line with improvements in the manufacturing technology of vehicles.
2. Consequently annexes 1, and 2 attached to this Supplementary Act, and which are part thereof shall be adapted or modified by a Decision of the Council of Ministers upon the recommendation of the sector Ministers.

Article 26 Other Obligations

1. A Member State shall not have the right to refuse or prohibit the use of vehicles registered or put into service in any other Member States on its territory for reasons pertaining to the dimensions and weight if such vehicles comply with the maximum values specified in annex 1 and 2 of this Supplementary Act.
2. The provision of paragraph 1 of this Article shall be applicable notwithstanding the fact that the said vehicles do not comply with the provisions of the laws of the Member State regulating some weight and dimension specifications that are not covered by this Supplementary Act.
3. No Member State shall authorize the normal circulation of vehicles or an assembly of vehicles on its territory if they do not comply with the specifications stated in this Supplementary Act.

Article 27 Transition period

1. During a one-year transition period starting from the date of entry into force stated in article 29 below, Member States shall put in place their road control system as specified below:
 - i. By the end of the first six months of the transition period, weighing equipment shall be acquired and made operational and temporary areas shall be developed as fixed control posts for the storage of goods offloaded from overloaded vehicles;
 11. By the end of the transition period, road control systems shall be set and made operational as defined in this Supplementary Act.
2. By the end of a two year period starting from the date of entry into force stated in Article 29 below, vehicles transporting hydrocarbons in circulation in the region and which do not comply with the standards Set forth in this Supplementary Act shall be modified to make them compliant.

3. A road map defining the modalities for the implementation of this Supplementary Act shall be established by the Council of Ministers on the recommendation of the transport Sectoral Ministers.

Article 28 Moratorium

1. In each Member State, a moratorium shall be applicable starting from the date of entry into force of this Supplementary Act as specified in paragraph (2) et (2) below.
2. A general moratorium limited to enforcement of fines shall be granted for a period of twelve (12) months during which only sanctions provided for under article 15 of the Supplementary Act shall be applied
3. Infringements shall be subject to a specific moratorium as follows:
 - Infringements which attract the sanction provided under paragraph C of Article 18 (4) of this Act: None for new vehicles or registered vehicles for the first time; (ii) one (1) year for other vehicles with the exception of Hydrocarbon transport Vehicle for which a period of two years has been granted;
 - Breach of provisions of Article 8 of this Supplementary Act: (i) none for new vehicles or vehicles registered for the first time; (ii) one (1) year for other vehicles with the exception of Hydrocarbon Transport Vehicles for which 2" years has been granted . .

Article 29 Publication

This Supplementary Act shall be published by the ECOWAS Commission in the Official Journal of the Community within thirty (30) days of its signing by the Heads of State and Government. It shall also be published by each Member State in its National Gazette within thirty (30) days of notification by the Commission.

Article 30 Entry into force

This Supplementary Act shall enter into force upon its publication. Consequently, Member States shall undertake to commence implementation of its provisions upon its entry into force.

Article 31 Miscellaneous Provisions

The Supplementary Act shall supersede any other contrary provisions.

Article 32 Depository Authority

This Supplementary Act shall be deposited at the Commission which shall forward certified copies to all Member States and shall register same with the African Union, United Nations Organisation and all other organisations selected by the Council.



IN FAITH WHEREOF, WE, THE HEADS OF STATE AND GOVERNMENT OF THE MEMBER STATES OF THE ECONOMIC COMMUNITY OF WEST AFRICAN STATES (ECOWAS), HAVE SIGNED THIS SUPPLEMENTARY ACT



DONE AT ABUJA, THIS 19TH DAY OF JULY, 2011

IN SINGLE ORIGINAL IN ENGLISH, FRENCH AND PORTUGUESE LANGUAGES, ALL TEXTS BEING EQUALLY AUTHENTIC.

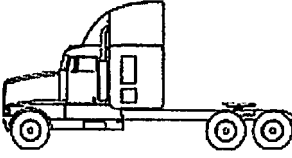
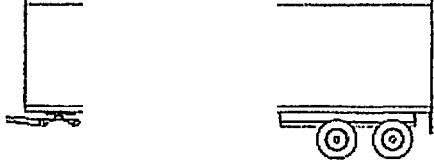
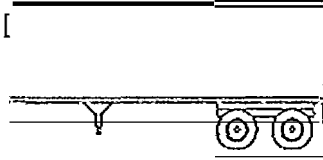
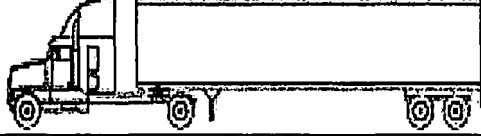
ANNEX 1 : DEFINITIONS RELATING TO THE DIMENSIONS, WEIGHT AND LOAD OF HEAVY-DUTY GOODS TRANSPORT VEHICLES

DEFINITIONS RELATING TO VEHICLE TYPES

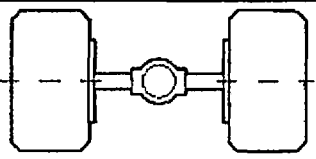
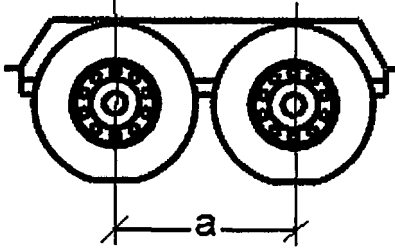
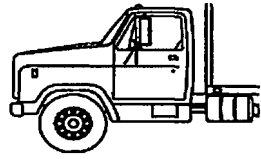
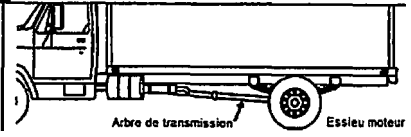
TERMS AND DEFINITIONS	BODY FRAME
<p>Heavy-duty <i>lcargo</i> vehicle</p> <p>Vehicle (or assembly of vehicles coupled to form a unit of traffic) whose authorized total travelling weight is above 3.5 tones</p>	
<p>Tractive unit</p> <p>A vehicle motorized so as to be self-propelling</p>	
<p>Cargo vehicle</p> <p>A motorized vehicle with a fixed cargo casing or platform, which bears its entire load on its frame.</p>	
<p>Road tractor</p> <p>A motorized (non-cargo) vehicle fitted with a "fifth wheel" as well as electrical and compressed air connections for semi-trailer lights and brakes.</p>	
<p>Truck trailer</p> <p>Non-motorized vehicle designed to be towed by a motorized vehicle. Truck trailer may also describe the last vehicle of a road train</p>	
<p>Semi-trailer</p> <p>Trailer without front axle, the wheelless part of which is designed to be coupled to a motorized towing vehicle such that part of this trailer rests on the motorized vehicle and that a substantial part of its weight and load weight rests on the said vehicle</p>	
<p>Articulated Vehicle</p> <p>Combination of vehicles consisting of a road tractor coupled to a semi-trailer</p>	
<p>Road train</p> <p>Vehicle combination consisting of a cargo vehicle</p>	

and a trailer or a semi trailer	
<p>Double road train</p> <p>Vehicle combination consisting of a tractor and two semi-trailers.</p>	
DEFINITIONS RELATING TO AXLE TYPES	
TERMS AND DEFINITIONS	BODY FRAME
<p>Load carrying axle</p> <p>A set of wheels mounted symmetrically on the same axle beam to support a portion of the load.</p>	
<p>Axle spread/spacing</p> <p>Distance between the centers of the axle beams connected to the same suspension</p>	 <p>a : axle spread</p>
<p>Front axle</p> <p>Steering axle located at the front end of a motor vehicle</p>	
<p>Steering axle</p> <p>Load carrying axle with wheels mounted on the pivoting components</p>	
<p>Powered axle</p> <p>Load carrying axle which receives driving force from the transmission and transmits to the wheels</p>	
<p>Single axle</p> <p>Axle system having only one load carrying axle</p>	

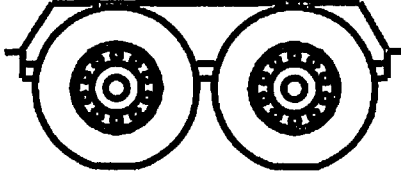
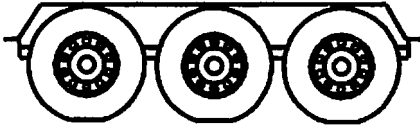
<p>Tandem axle / Double axle</p> <p>Axle system composed of two axles, either of which may be powered or non-powered</p>	Type 1 $a \leq 1\text{m}$	
	Type 2 $t\text{m} \leq a \leq t,5\text{m}$	
	Type 3 $1,3\text{m} \leq a \leq 1,8\text{m}$	
	Type 4 $a \geq 1,8\text{m}$	
	Type 5 $a \leq 2,3\text{t}$	
<p>Triple axle or tri-axle</p> <p>Running gear consisting of an assembly of three evenly spread load-carrying axles mounted on the same suspension</p>	Type 1 $a \leq 1,3\text{m}$	
	Type 2 $1,3\text{m} \leq a \leq 1,4\text{m}$	
	Type 3 27t a	
	Type 3 27t a	
Twin or dual wheels	Dual wheels on each side of an axle	
DEFINITIONS RELATING TO DIMENSIONS		
Overall external dimensions	Dimensions (length width and height) inclusive of all protrusions, load and accessories	
Dimensions	Overall dimension or size (length, width and height) of an assembly of vehicles cargo unit inclusive	
Maximum authorized dimensions	Permissible maximum dimensions for a vehicle in circulation	
DEFINITIONS RELATING TO VEHICLE WEIGHT		
Axle load (AL)	Portion of vehicle weight borne by the axle	

Authorized maximum axle load (AMAL)	The maximum axle load statutorily permissible for a vehicle in circulation on public road
Authorized total laden weight (ATLW)	The maximum total weight statutorily permissible for a laden vehicle in circulation
Authorized total operational weight (ATOW)	The maximum total weight statutorily permissible for an assembly of laden vehicles in circulation
OTHER DEFINITIONS	
Vehicle driver	The person driving the vehicle at the time under control. This person could be the owner himself or an employee of the owner or any other person offering his services to the owner for a fee or free of charge
Vehicle operator/ transporter	A corporate body or an individual who uses a vehicle to transport goods on his own account or for another person. The vehicle belongs to the operator or hired by operator. In any other case, the operator is the same as the owner of the vehicle; it is the special case where the vehicle is borrowed.
Shipper or Consignor	Individual or corporate body owner or representative of cargo unit owner for whom the cargo is being transported
Traffic generating Platform	
Way bill	A written record of the contract between the transporter and the shipper as provided in the OHADA Uniform Act (stated above) regulating road transport of goods. The shipper shall also be defined as the consignee.
Moratorium	Period starting from the entry into force of this Regulation during which none of the monetary sanctions shall be applied.
Road control system operator or operator	A public or private corporate body managing and operating a road control system to check the dimensions, weight and axle load of vehicles
Common land exit/entry platform	A border platform hosting the joint border control post and considered as a common land entry and exit point of two sharing a common border
Joint border control post	A place developed and equipped, near the border in one of two neighboring countries, housing the post used by both border control services at the borders of the two neighboring countries to conduct border control operations at the exit point of one country and entry point for the others.
ISRT	Inter-State Road Transit

ANNEX 2 : DIMENSION, WEIGHT AND AXLE LOAD STANDARDS FOR HEAVY-DUTY CARGO TRANSPORT VEHICLES

DIMENSION LIMIT FOR HEAVY-DUTY CARGO TRANSPORT VEHICLES

DIMENSIONS	VEHICLE	MAXIMUM AUTORISED
LENGTH INCLUSIVE OF ALL PROTRUSIONS, LOAD AND ACCESSORIES	Cargo carrier - Single engine vehicle	12 m
	Semi-trailer (between the kingpin and the back)	12 m
	Trailer (without coupling mechanism)	12 m
	Articulated Vehicle	18.75 m
	Road train Coupled assembly of vehicles (cargo carrier + trailer)	18.75 m
	Double train for car transportation	18.00 m
	Double train for container transportation	24.20 m
	Other road train/double train	22m
WIDTH INCLUSIVE OF ALL PROTRUSIONS, LOAD AND ACCESSORIES	Transport vehicle with controlled temperature	2.65 m
	Other vehicles	2.55 m
	Trailer with « twist lock »	2.70 m
HEIGHT INCLUSIVE OF ALL PROTRUSIONS, LOAD AND ACCESSORIES	Any vehicles	4.50 m

AUTHORIZED MAXIMUM AXLE LOAD (AMAL)

AXLE TYPE	AMAL	
Single front axle	9t	
Single intermediary or rear axle	Single wheel	11.5 t
	Twin wheels	12 t
Dual (tandem) intermediary or rear axle	Type 1	11.5t

	Type 2	16t
	Type 3	18t
	Type 4	20t /23t
Triple axle (tri-axle)	Type 1	21t
	Type 2	25t
	Type 3	27t
	Type 4	31.5t

AUTHORIZED TOTAL WEIGHT OF SOME COMMON VEHICLES

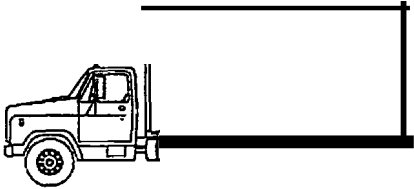
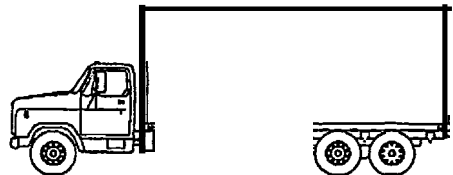
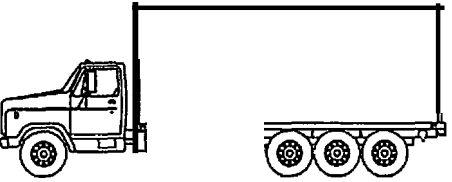
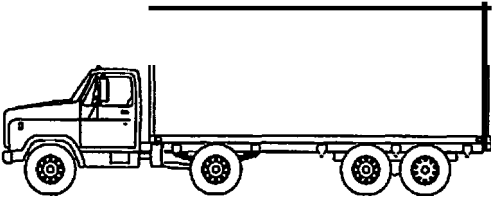
VEHICLE	ATLW	VEHICLE	ATLW
<p>Vehicle with 2 axles (9; 12) P11</p> 	<p>18 tonnes 2</p>	<p>Vehicle with 3 axles, one of which is type tandem type4 (9 ;23t) P12</p> 	<p>26 tonnes</p>
<p>3</p> <p>Vehicle with 4 axles, one of which is tridem type 2 (9 ;27t), P13</p> 	<p>31 tonnes</p>	<p>3b</p> <p>Vehicle with 4 axles, one of which is tandem type 2 (9; 12; 23) P112</p> 	<p>31 tonnes</p>

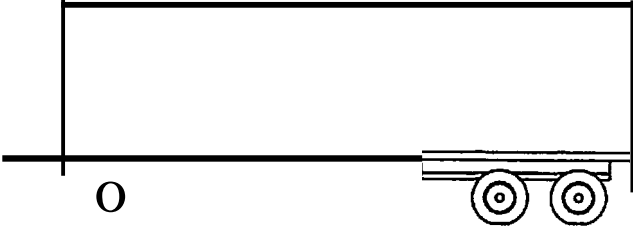
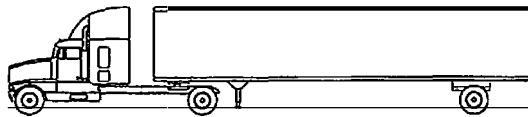
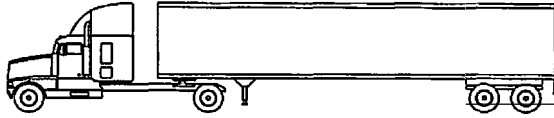
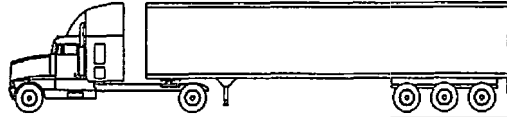
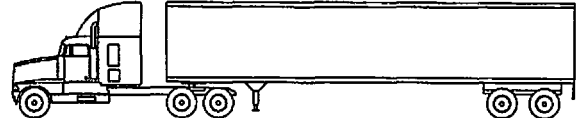

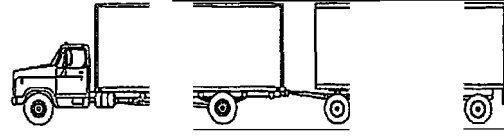
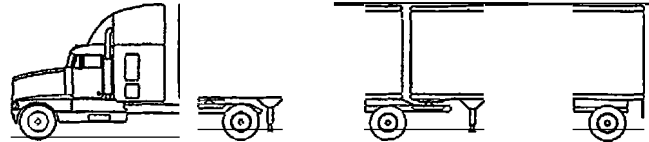
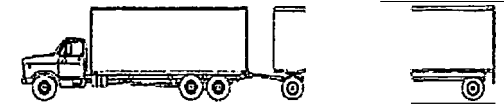

4	Trailer with 2 axle (9 ; 12t) <u>R11</u> 	18 tonnes	5	Trailer with three axles, one of which is a tandem (9 ;23t) <u>R12</u> 	26 tonnes
VEHICULE		PTRA	VEHICULE		PTRA
6	Articulated vehicle with 3 axles (9; 12; 12t) <u>T11S1</u> 	30 tonnes	7	Articulated vehicle with 4 axles, one of which is tandem type 4 (9; 12; 23t) <u>T11S2</u> or (9; 23 ; 12), <u>T12S1</u> 	38 tonnes
8	Articulated vehicle with 5 axles, one of which is tridem type 2. (9; 12; 27t), <u>T11S3</u> 	43 tonnes	9	Articulated vehicle with 5 axles, two of which are tandem type 4 (9 ;23 ;23t) <u>T12S2</u> 	46 tonnes

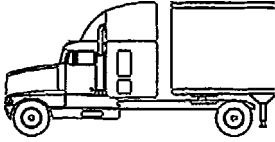
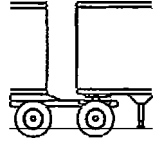
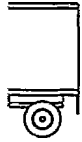
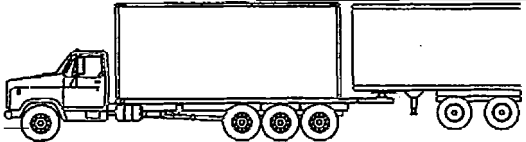
10	Articulated Vehicle with 6 axles, with 1 tandem type 4 and 1 tridem type 2 (9 ;23 ;27) <u>T1253</u> Six axle or more vehicle	51 tones
		

	VEHICULE	PTRA	VEHICULE	PTRA
11	Road Train (cargo vehicle - trailer with four simple axle (9 ;12 ;12 ;12) <u>P11R11</u>	38tonnes	Dual train with 4 simple axle (9; 12 ; 12 ; 12) <u>T1151 51</u>	38tonnes
		11b		
12	Road Train (cargo vehicle + trailer) with 5 axle (9; 20; 12; 12) <u>P12R11</u> or (9; 12; 12; 20) <u>P11R12</u>	44tonnes	Double Train with 5 axle (9;12;23;12) <u>T1152S1</u> or (9;23;12; 12) <u>T12S1S1</u>	44tonnes
		12b		

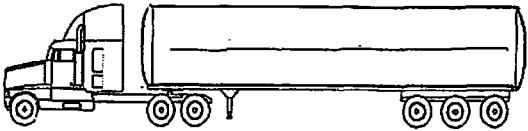
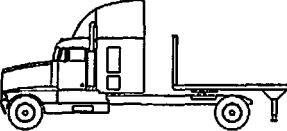
				  	
12c	Road Train (cargo vehicle - trailer) with 6 axle (9; 23; 9; 23) — P12R12	44tonnes	12d	Double train with 6 axle (9; 23; 23 ; 12) T12S2S1	44tonnes
13	Six axle Road Train (cargo vehicle + trailer) (9; 27 ; 23) P13S2	51tonnes			
					

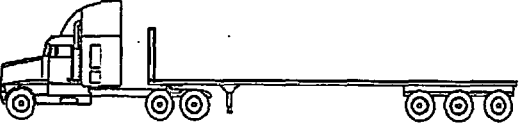
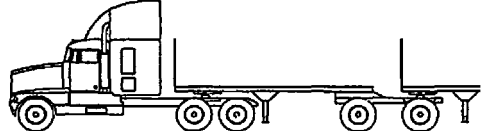
	VEHICULE	PTRA		VEHICULE	PTRA
14	Articulated vehicle with 6 axle for HYDROCARBON TRANSPORT (9; 23; 31,S) T12S3	59tonnes *	5	Articulated vehicle with 5 axle for CONTAINER COMBINED TRANSPORT (9; 12; 31,5) T11S3	46tonnes

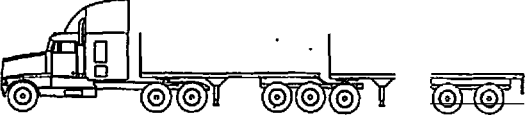
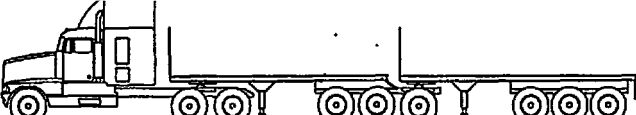
			 	
<p>16</p>	<p>Articulated vehicle with 6 axle for CONTAINER COMBINED TRANSPORT (9; 23; 31,5) <u>T12S3</u></p> 	<p>56tonnes</p>	<p>17</p> <p>Articulated vehicle with 7 axle for CONTAINER COMBINED TRANSPORT (9; 23 ; 23 ; 23) <u>T12S2S2</u></p>  	<p>64tonnes</p>
<p>18</p>	<p>Articulated vehicle with 8 axle for CONTAINER COMBINED TRANSPORT (9; 23; 31,5; 23) <u>T12S3S2</u></p> 	<p>75tonnes</p>	<p>19</p> <p>Articulated vehicle with 9 axle for CONTAINER COMBINED TRANSPORT (9; 23; 31,5; 31,5) <u>T12S3S3</u></p> 	<p>80 tonnes</p>



SIXTY-SIXTH ORDINARY SESSION
OF THE COUNCIL OF MINISTERS

Abuja 17 - 19 August 2011

RECOMMENDATION C/REC.2 108/11 RELATING
TO THE ADOPTION OF THE ECOWAS MINERAL DEVELOPMENT
POLICY (EMDP) AND THE ATTACHED IMPLEMENTATION
MATRIX

THE COUNCIL OF MINISTERS,

MINDFUL of Articles 10, 11 and 12 of the ECOWAS Treaty as amended, establishing the Council of Ministers and defining its composition and functions;

MINDFUL of Article 31 of the said ECOWAS Treaty that provides that Member States shall harmonize and coordinate their policies and programmes in the field of natural resources and also coordinate their programmes for development and utilization of mineral and water resources;

MINDFUL of Regulation C/REG.3/5/09 relating to the development of Mineral Resources and the organization of the mining sector within ECOWAS;

MINDFUL of Directive C/DIR.3/5/09 relating to the Harmonization of Guiding Principles and Policies in the Mining Sector, enjoining Member States to take the required measures for the implementation of the said Directive and of its Action Plan by 01 July 2014;

MINDFUL of Supplementary Protocol AP/SP1/12/01 of 21 December 2001 on Democracy and Good Governance which provides the principles of good political, economic and social governance;

MINDFUL also of the ECOWAS Protocol AIP1/5/79 of May 1979 on Free Movement of People and Goods;

MINDFUL of Supplementary Act A/ISA4/12/08 relating to the ECOWAS ENVIRONMENT Policy;

CONSCIOUS of the need to promote a Mineral sector environment conducive to sustainable macroeconomic development and thus ensure a balance between incentives to investors and protection of the income base and resources of Member States;

AWARE of the need to acquire basic geological and mineral information through a systematic programme;

ACKNOWLEDGING the importance and specific needs of Artisanal and Small Scale Mining;

RECOGNIZING the need for Member States to develop, manage and promote their mineral resources so as to maximize the benefits of mineral revenue that accrue from mineral exploration;

RECOGNIZING also the need to promote the participation of national private sector and public private partnership in the mineral sector which encourage the acquisition of skills and increase professional opportunities for Member States citizens;

CONVINCED that in order to ensure the effective implementation of an ECOWAS Mineral Development Policy, it is imperative to attach a coherent and realistic Implementation Matrix that will ensure the development of capacity building programmes in Member States;

AWARE of the need to protect and preserve the environment, the health and safety of mining Communities from the negative impacts of mineral development operations, especially in mineral rich areas;

DESIROUS of adopting a harmonized institutional legal and regulatory framework in the mineral sector which is modern, transparent, accessible, competitive and in line with international best practice;

ON THE PROPOSAL of the third Meeting of ECOWAS Ministers in charge of Mineral Resource Development held in Accra on 3rd June 2011;

RECOMMENDS to the Authority of Heads of State and Government to adopt the attached Draft Supplementary Act on the ECOWAS Mineral Development Policy and its Implementation Matrix.

DONE AT ABUJA, THIS 19TH DAY OF AUGUST 2011

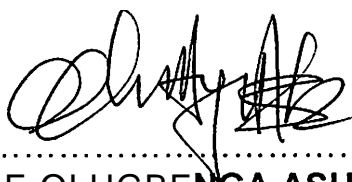

.....
H.E. OLUGBENGA ASHIRU

CHAIRMAN

FOR COUNCIL

FORTIETH ORDINARY SESSION OF THE AUTHORITY
OF HEADS OF STATE AND GOVERNMENT

Abuja, ... 2011

SUPPLEMENTARY ACT AISP.3/08/11 ADOPTING
THE ECOWAS MINERAL DEVELOPMENT POLICY (EMDP)
AND ITS IMPLEMENTATION MATRIX

THE HIGH CONTRACTING PARTIES,

MINDFUL of Articles 7, 8 and 9 of the ECOWAS Treaty as amended, establishing the Authority of Heads of State and Government and defining its composition and functions;

MINDFUL of Article 31 of the said ECOWAS Treaty signed in Cotonou on 24 July 1993 that prescribes that Member States shall harmonize and coordinate their policies and programmes in the field of natural resources and also coordinate their programmes for development and utilization of mineral and water resources;

MINDFUL of Regulation C/REG.3/5/09 relating to the development of Mineral Resources and the organization of the mining sector within ECOWAS;

MINDFUL of Directive C/DIR.3/5/09 relating to the Harmonization of Guiding Principles and Policies in the Mining Sector, enjoining Member States to take the required measures for the implementation of the said Directive and of its Action Plan by 1st July 2014;

MINDFUL of Supplementary Protocol AP/SP1/12/01 of 21 December 2001 on Democracy and Good Governance which prescribes the principles of good political, economic and social governance;

MINDFUL also of ECOWAS Protocol AIP115179 of May 1979 on Free Movement of People and Goods;

MINDFUL of Supplementary Act AISA4112108 relating to ECOWAS ENVIRONMENT Policy;

CONSCIOUS of the need to promote a Mineral sector environment conducive to sustainable macroeconomic development and thus ensure a balance between incentives to investors and protection of the income base and resources of Member States;

AWARE of the need to acquire basic geological and mineral information through a systematic programme;

ACKNOWLEDGING the importance and specific needs of Artisanal and Small Scale Mining;

RECOGNIZING the need for Member States to develop, manage and promote their mineral resources so as to maximize the benefits of mineral revenue that accrue from mineral exploration;

RECOGNIZING also the need to promote the participation of national private sector and public private partnership in the mineral sector which encourages the acquisition of skills and increases professional opportunities for Member States citizens;

CONVINCED that in order to ensure the effective implementation of an ECOWAS Mineral Development Policy, it is imperative to attach a coherent and realistic Implementation Matrix that will ensure the development of capacity building programme in Member States;

AWARE of the need to protect and preserve the environment, the health and safety of mining Communities from the negative impacts of mineral development operations, especially in mineral rich areas;

DESIROUS of adopting a harmonized institutional legal and regulatory framework in the mineral sector which is modern, transparent, accessible, competitive and in line with international best practice;

ON THE PROPOSAL of the third Meeting of ECOWAS Ministers in charge of Mineral Resource Development held in Accra on 3rd June 2011 ;

ON THE RECOMMENDATION of the sixty-sixth Ordinary Session of the Council of Ministers held in Abuja from 17th to 19th August 2011;

AGREE AS FOLLOWS:

Article 1

By this Supplementary Act, the ECOWAS Mineral Development Policy and its Implementation Matrix are hereby adopted.

Article 2

The general vision of the ECOWAS Mineral Development Policy shall be to promote the harnessing of mineral resource capital, facilitate sustainable economic growth and integrated socio-economic development in the region.

Article 3

The overall objective of the ECOWAS Mineral Development Policy shall be to promote the development of an efficient mineral sector in the region by improving geological and mineral information, regulating and developing Artisanal and Small Scale Mining and ensuring the mainstreaming of Mineral Operators Corporate Social Responsibility in local development plans of Mineral Communities.

Article 4

Member States shall ensure the harmonization of the national mineral policies with the ECOWAS Mineral Development Policy referred to in Article 1 of this Supplementary Act.

Article 5

The ECOWAS Commission shall take necessary measures to diligently implement the ECOWAS Mineral Development Policy and its Implementation Matrix.

Article 6

This Supplementary Act shall be published by the ECOWAS Commission in the official journal of the Community within thirty (30) days after its signature. It shall also be published by each Member State in its official Gazette thirty (30) days after its notification by the Commission.

Article 7

1. This Supplementary Act shall enter into force upon its publication. Consequently, signatory Member States undertake to commence the implementation of its provision on its entry into force.
2. This Supplementary Act shall be attached as an annex to the ECOWAS Treaty of which it forms an integral part.

Article 8

This Supplementary Act shall be deposited with the Commission which shall submit certified true copies thereof to all Member States and shall register it with the African Union, the United Nations and such other organizations as Council may determine.

IN WITNESS WHEREOF, WE, THE HEADS OF STATE AND GOVERNMENT OF THE ECONOMIC COMMUNITY OF WEST AFRICA, HAVE SIGNED THIS SUPPLEMENTARY ACT.

DONE AT ABUJA THIS 19TH DAY OF AUGUST 2011

IN SINGLE ORIGINAL IN THE ENGLISH, FRENCH AND PORTUGUESE LANGUAGES, ALL THREE (3) TEXTS BEING EQUALLY AUTHENTIC.



SIXTY-SIXTH ORDINARY SESSION OF THE COUNCIL OF MINISTERS

Abuja, 17 - 19 August 2011

RECOMMENDATION C/REC.3/8/11 RELATING TO THE SANCTIONS AGAINST MEMBER STATES THAT FAIL TO HONOUR THEIR OBLIGATIONS TO ECOWAS

THE COUNCIL OF MINISTERS,

MINDFUL of Articles 10, 11 and 12 of the ECOWAS Treaty as amended, establishing the Council of Ministers and defining its and composition and functions;

RECALLING that ECOWAS has created supranational bodies whose decisions are binding and therefore, applicable directly and in their entirety in Community Institutions as well as in Member States, with the aim of enhancing their effectiveness;

RECALLING also that ECOWAS has granted its political and judicial Institutions the capacity to enforce compliance and apply the decisions of its supranational bodies;

CONSIDERING that Article 77 of the ECOWAS Treaty stipulates that the Authority can impose sanctions against Member States that fail to honour their obligations to the Community;

CONSIDERING that the Protocol AISP1/12/01 on Democracy and Good Governance, supplementing the ECOWAS Protocol relating to the Mechanism for Conflict Prevention, Management, Resolution, Peacekeeping and Security in its Article 45, stipulates that the Community can impose different sanctions on Member States where democracy has been disrupted through whatever means;

CONSIDERING that Article 9 of the Supplementary Protocol A1SP1.101/05 amending the Protocol relating to the Court of Justice grants this Court the competence to consider cases of non-fulfilment by Member States of obligations incumbent upon them by virtue of the ECOWAS Treaty, Conventions and Protocols, Regulations, Decisions and Directives ;

NOTING that the Community provisions in force do not define the obligations, for which non-application or non-fulfilment exposes Member States to sanctions;

DESIRING to establish appropriate sanctions and ensure suitable, just and equitable application;

CONVINCED that the Community can only impose sanctions which are effective and actually applicable against Member States or their leaders, if it has a well-defined sanctions system;

DESIROUS to adopt a system comprising obligations which if unfulfilled, may lead to the imposition of sanctions, and a system that brings together in a single document the range of applicable sanctions, defining the modalities for the implementation of the said sanctions by specifying in particular, the procedures for imposing and lifting sanctions;

RECOMMENDS to the Authority of Heads of State and Government to adopt the Draft Supplementary Act on Sanctions against Member States that fail to honour their Obligations to ECOWAS

DONE AT ABUJA, THIS 19TH DAY OF AUGUST 2011

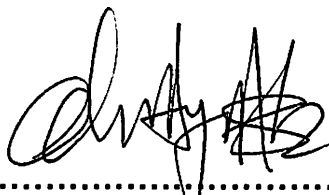

.....
H.E. OLUGBENGA ASHIRU

CHAIRMAN

FOR COUNCIL

**FORTIETH ORDINARY SESSION OF THE AUTHORITY
OF HEADS OF STATE AND GOVERNMENT**

Abuja, 2011

**SUPPLEMENTARY ACT A/SP.2/08/11 ON SANCTIONS AGAINST
MEMBER STATES THAT FAIL TO HONOUR THEIR OBLIGATIONS
TO ECOWAS**

THE HIGH CONTRACTING PARTIES,

MINDFUL of Articles 7, 8 and 9 of the ECOWAS Treaty as amended, establishing the Authority of Heads of State and Government and defining its composition and functions;

RECALLING that ECOWAS has created supranational bodies whose decisions are binding and therefore applicable directly and in their entirety in Community Institutions as well as in Member States with the aim of enhancing their effectiveness;

RECALLING also that ECOWAS has granted its political and judicial Institutions the capacity to enforce compliance and apply the decisions of its supranational bodies;

CONSIDERING that Article 77 of the ECOWAS Treaty stipulates that the Authority can impose sanctions against Member States that fail to honour their obligations to the Community;

CONSIDERING that the Protocol AISP1/12/01 on Democracy and Good Governance, supplementing the ECOWAS Protocol relating to the Mechanism for Conflict Prevention, Management, Resolution, Peacekeeping and Security in its Article 45, stipulates that the

Community can impose different sanctions on Member States where democracy has been disrupted through whatever means;

CONSIDERING that Article 9 of the Supplementary Protocol A1SP1.101/05 amending the Protocol relating to the Court of Justice grants this Court the competence to consider cases of non-fulfilment by Member States of obligations incumbent upon them by virtue of the ECOWAS Treaty, Conventions and Protocols, Regulations, Decisions and Directives ;

NOTING that the Community provisions in force do not define the obligations, for which non-application or non-fulfilment exposes Member States to sanctions;

DESIRING to establish appropriate sanctions and ensure suitable, just and equitable application;

CONVINCED that the Community can impose sanctions which are effective and actually applicable against Member States or their leaders, if it has a well-defined sanctions system;

DESIROUS to adopt a system comprising obligations which if unfulfilled, may lead to the imposition of sanctions, and a system that brings together in a single document the range of applicable sanctions, defining the modalities for the implementation of the said sanctions, by specifying in particular, the procedures for imposing and lifting sanctions;

ON THE PROPOSAL of the Meeting of Ministers of Justice of Member States held in Abuja on 16 to 17 May 2011;

ON THE RECOMMENDATION of the sixty-sixth ordinary session of the Council of Ministers held in Abuja from 17 to 19 August 2011;

AGREE AS FOLLOWS:

CHAPTER 1

OBLIGATIONS FOR WHICH NON-FULFILMENT IS LIKELY TO ENGENDER SANCTIONS AGAINST MEMBER STATES

Article 1 Definition of Obligation of Member States

1. Member States shall apply and respect Acts of the Authority and Council of Ministers which include the ECOWAS Treaty, Conventions, Protocols Supplementary Acts, Regulations, Decisions, Directives of the Community as well as the decisions of the Community Court of Justice.

Article 2 Categories of obligations of Member States

1. The obligations contained in the Acts described in Article 1 paragraph 2 of this Supplementary Act are divided into two categories. They are those Acts that aim to create within Member States and at the regional level, an atmosphere of true and lasting peace, void of all threat and violation of the constitutional order and those which aim at strengthening and accelerating the process of regional integration.
2. The following shall among others constitute the obligations of Member States, to:
 - i) respect and protect Human Rights, the Rule of law, democracy and constitutional order;
 - ii) ratify ECOWAS Protocols and Conventions;
 - iii) dismantle tariff and non-tariff barriers which hinder the free movement of persons, goods, the right of residence and establishment;
 - iv) pay all financial obligations in general and in particular apply the texts in the Community Levy;
 - v) promptly apply texts adopting the integration policies, projects and programmes of the Community;

- vi) apply the mandatory texts enumerated under Article 1 paragraph 1 of this Supplementary Act;
 - vii) prohibit the adoption of measures or positions contrary to democratic governance and respect for the Rule of Law, or likely to constitute either a serious threat to regional security or gross and severe human rights abuses, or trigger a humanitarian disaster;
 - viii) refrain from adopting and implementing all measures likely to subvert or compromise the strengthening of the process of regional integration.
4. The decisions of the ECOWAS Community Court of Justice are binding on Member States.

CHAPTER 2

SANCTIONS APPLICABLE IN THE EVENT OF NON-FULFILMENT OF OBLIGATIONS

Article 3 Principle of Sanctions

1. Member States or their leaders that fail to honour their obligations to the Community shall be liable to judicial and political sanctions.
2. Leaders of Member States, members of their families and their associates shall also have sanctions imposed on them as stipulated in paragraph 1 of this Article.

Article 4 Purpose of sanctions

1. The aim of imposing sanctions must be to prevent the non-respect or non-application of mandatory Acts defined in Article 1 of this Supplementary Act from having harmful effects on the functioning of the Community and its Institutions. It is to prevent such behaviour by Member States compromising the

implementation of Community programmes and lead to gradual blockage in the activities of the Community.

2. Sanctions must encourage Member States to respect and enforce all mandatory Acts of the Community. They must promote the elimination of all obstacles to regional integration and facilitate the achievement of Community goals.
3. To be effective, sanctions to be imposed against Member States must aim at creating conditions for the restoration of normal constitutional processes when they are imposed; for example in the case of a breakdown in democracy. They also allow for the righting of a wrong or the acknowledgement of a right denied a citizen, where this right has been conferred by a mandatory Act. The aim of sanctions must be to strengthen the Community and make her more effective.
4. As far as it is possible, sanctions shall not affect the delivery of humanitarian aid to people in the concerned Member State.

Article 5 Judicial Sanctions

The Court of Justice may deliver judgements sanctioning Member States for failure to comply with their obligations under the Treaty, the Conventions and Protocols, Regulations, Decisions and Directives of ECOWAS.

Article 6 Political sanctions

Sanctions applicable against Member States that do not honour their obligations to the Community may include:

- (i) suspension of any new loans or new assistance granted by the Community;
- (ii) suspension of disbursements for all ongoing loans, projects and Community assistance programmes;
- (iii) non-acceptance of applications to statutory and professional positions within Community Institutions;
- (iv) suspension of the right to vote;

- (v) suspension from participation in Community activities;
- (vi) non-support of applications presented by Member States to elective positions in international organisations;
- (vii) refusal to organise meetings in the concerned Member State;
- (viii) suspension of the concerned Member State from all ECOWAS decision-making organs. During the suspension period, the concerned Member State shall continue to pay its contributions to the Community;
- (ix) travel ban on the leaders their families and their associate, notwithstanding community provisions on free movement of persons;
- (x) freeze their financial assets;
- (xi) recall by other Member States of their Ambassadors from the country where there is a breakdown of democracy;
- (xii) embargo on arms entering the concerned Member State;
- (xiii) ban on contesting for the Chairmanship of the Community;
- (xiv) condemnation and refusal to acknowledge unconstitutional Governments;
- (xv) Peace enforcement or restoration of constitutional order by use of legitimate force.

Article 7 Definition of the content of some sanctions

To facilitate consistent and equal application to all Member States, the envisaged sanctions shall be defined in the provisions of this Supplementary Act.

Article 8 Suspension from participation in ECOWAS activities

1. When a Member State is suspended from participating in the activities of the Community, these activities shall include all

activities organised or co-organised by ECOWAS, as well as outside the sub-region.

2. When a Member State is suspended from participating in ECOWAS activities, ECOWAS Institutions shall not invite or admit the representatives of this country to its meetings, regardless of the place where these meetings are held. ECOWAS Institutions shall suspend the implementation or monitoring of on-going projects and programmers in this country. All consultations with leaders of the suspended Member States regarding Community activities shall cease.
32. The leaders of the suspended Member States shall not sit on any committee set up by ECOWAS to prepare or monitor the implementation of Community projects or to manage or settle issues regarding the Community. No leader of the suspended country shall be a member of any ECOWAS delegation representing the Community before international bodies or in the implementation of any Community activity.
4. The territory of the suspended Member State shall not be used to hold any meeting nor event organised or supported by ECOWAS.

Article 9 Travel ban on leaders, their families and associates

1. When leaders of a Member State, members of their families and associates are banned from travelling, the other Member States, without prejudice to the fullness of their powers and the relevant provisions of the ECOWAS Protocols on Free Movement of Persons, Goods, the Right of Residence and Establishment, shall:
 - a) impose on them restrictions on any travel they shall make to the other Member States;
 - b) impose restrictions on the use of their airspace or territorial waters;
 - c) expel them from their territory;

2. The afore-mentioned travel restrictions shall apply on all occasions except when the leaders under the travel ban are invited by ECOWAS, African Union, European Union and the United Nations or when the travel is for humanitarian reasons.

Article 10 Recall by other Member States of their
Ambassadors accredited to a country

When the Authority of Heads of State and Government decides on other Member States recalling their Ambassadors accredited to a country, all diplomatic relations with that country shall also be suspended.

Article 11 Embargo on arms entering a Member State

1. When the Authority of Heads of State and Government decides to place an embargo on arms entering a Member State, other Member States shall put in place an embargo on the delivery of arms, ammunitions, and military equipment to this country. Other Member States shall prevent:
 - a) the sale and/or supply to a country under embargo, by their citizens or from their territory, or through their ships or aircrafts, of weaponry and related materials of all types, including arms and ammunitions, military vehicles and equipments, police equipment and related spare parts;
 - b) entry to the territorial waters of the country under embargo, of any means of transport carrying weaponry or related materials of all types, including arms and ammunitions, military and police vehicles and related spare parts.
2. When an arms embargo has been placed against a country, the President of the Commission shall not accede to any requests for exemption from the application of the provisions of the ECOWAS Convention on Small Arms and Light Weapons. The President of the Commission shall cease to notify the leaders of the country under embargo, of requests for exemption from the application of the Convention on Small Arms and Light Weapons that he may receive from other Member States, and the responses he will give to such requests.

3. Other Member States shall ensure the strict surveillance of their coastal areas, land borders and air spaces, in order to prevent any violation of the arms embargo by the country against which this sanction has been imposed.

Article 12 Ban on standing for Presidential office in Member States

The perpetrators of Coup d'Etat and their accomplices, governments seeking to remain in power and prevent any possibility of alternation by changing the constitution, as well as participants and beneficiaries of all other anti-constitutional changes shall not stand for presidential office in their respective Member State. ECOWAS and its Member States shall not recognise governments arising from power obtained through such means.

CHAPTER 3

MODALITIES FOR IMPLEMENTING SANCTIONS

Article 13 Application of sanctions

The sanctions defined in Articles 5 to 11 of this Supplementary Act shall be enforced in gradual or cumulative manner.

Article 14 Power of Initiative

The procedure for the application of sanctions against Member States that fail to honour their obligations to the Community shall be implemented:

- a) upon decision of the Authority of Heads of State and Government;
- b) at the request of a Member State;
- c) on the recommendation of the President of the Commission.

Article 15 Allegations of non-compliance or non fulfilment of obligations by Member States

1. Cases of non-compliance or non-fulfilment by Member States of their obligations to the Community may be reported by any individual or corporate entity of a Member State, any Community Institution, Member State and may be ascertained by the Council of Ministers of the Authority of Heads of State and Government.
2. The allegations by individuals and corporate entities shall be addressed to National Authorities responsible for regional integration or the President of the Commission. When these allegations are addressed to national authorities, the latter shall forward same to the President of the Commission without delay. Allegations by Institutions shall be addressed to the President of the Commission. All allegations shall be presented to the Council of Ministers through the President of the Commission.
3. The President of the Commission shall notify the Member State concerned of the allegation against it and informs it that it has a period of thirty (30) days with effect from the date of notification, to honour the obligations which it is accused of failing to honour, or present a case in its defence.
4. At the expiration of the afore-mentioned thirty (30) days deadline, the President of the Commission shall have a thirty (30) days period to verify whether the concerned Member State has honoured its obligations to the Community. If this is the case, the President of the Community shall inform the initiator of the allegation and present a report to the Council of Ministers at its next Session.

Article 16 Indictment against a Member State that fails to honour its obligations to the Community

1. If, following investigations by the President of the Commission, it is revealed that the Member State has failed to respect or fulfil its obligations, and that after the start of the investigations, the concerned Member State has made no effort to remedy this, the

President of the Commission shall make a report contained in a Memorandum addressed to the Council of Ministers.

2. The Council of Ministers shall consider the Memorandum presented by the President of the Commission and set a deadline for the concerned Member State within which it must honour the obligations it is being accused of having failed to respect or fulfil.
3. If at the end of the deadline set by the Council of Ministers, the concerned Member State has still not fulfilled its obligations, the Council of Ministers shall make recommendations to the Authority of Heads of State and Government on the sanctions to be imposed on the concerned Member State, their leaders, members of their families and associates. The Authority shall impose appropriate sanctions.
4. Sanctions imposed against any Member State shall not be subject to appeal before the Community Court of Justice or any other court.

Article 17 Notification of sanctions

1. Member States shall be immediately notified of sanctions imposed on them. Other Member States as well as all Community Institutions shall also receive notifications by the President of the ECOWAS Commission.
2. The notification referred to in paragraph 1 of this article shall be published in the Official Journal of the Community by the ECOWAS Commission.

Article 18 Application of sanctions and monitoring of their implementation

1. All Member States and Community Institutions shall take the necessary measures to ensure that the Decisions by which sanctions are imposed are fully applied.
3. The President of the ECOWAS Commission shall put in place a Committee for monitoring the implementation of sanctions. The Commission shall, within its means, render the assistance

required by the concerned Member State to carry out the obligations it has failed to honour.

3. The composition of the Committee shall be defined by an enabling rule of the President of ECOWAS Commission.

Article 19 Suspension of Application of Sanctions against a Member State

1. Any Member State, that temporarily finds itself unable to honour the obligations described in Articles 1 of this Supplementary Act for reasons such as disasters or exceptional circumstances that seriously affect its economy, peace, security and political stability, shall inform the President of the Commission of the circumstances without delay.
2. When, in application of paragraph 1 of this Article, the President of the Commission is informed, the latter shall make a report to the Council of Ministers requesting that no sanctions be taken against the concerned Member State or that the provisions on sanctions be benevolently enforced on the Member State, until such a time as the disasters or exceptional circumstances affecting the country no longer exist.

Article 20 Suspension of sanctions

1. If no session of the Council of Ministers and the Authority of Heads of State is held in the two (2) months following the observation by the President of the Commission that the Member State concerned has fulfilled its obligations, the President of the Commission shall propose to the current Chairman of the Council of Ministers, who is acting on behalf of the Authority, to suspend the sanctions taken against the concerned Member State.
2. The President of the Commission shall inform the Council of Ministers of the recommendations of its Chairman and the suspension decision taken by the Chairman of the Authority at the next session of the Council
3. A Member State which fails to honour its obligations shall after sanction proceedings have been commenced against it, present a request to the Council of Ministers through the President of the

Commission, for a special time frame allowing it to ensure the respect and fulfilment of its obligations. In this case, the Chairman of the Council of Ministers, on behalf of the Council of Ministers, shall make recommendations to the Chairman of the Authority of Heads of State and Government on the suspension of the sanctions proceedings. The Chairman later acting on behalf of Authority, after private consultation with his peers, may accede to the request.

4. If at the end of the special time frame, the defaulting Member State honours its obligations, no sanction procedure will be taken against it. If the Member State does not honour its obligations, the Authority shall impose appropriate sanctions against it.

Article 21 Lifting of Sanctions

1. Once it has honoured its obligations, the Member State under sanctions shall inform the President of the Commission of its compliance. The President of the Commission, after ensuring that this is the case, shall present a report to the Council of Ministers by way of a Memorandum. The Council of Ministers, after having noted that the sanctions are no longer necessary, shall recommend their immediate removal to the Authority of Heads of State and Government.
2. Sanctions shall be lifted if, from the opinion of the Heads of State and Government, and on the basis of a substantiated report prepared by an independent body set up by the President of the Commission, the concerned Member State failed to honour its obligations due to reasons and circumstances beyond its control and if, the defaulting Member State satisfies conditions allowing for the sanctions against it to be lifted.

CHAPTER 4

FINAL PROVISIONS

Article 22 Amendment and Revision

1. Any Member State, the Council of Ministers or the ECOWAS Commission may submit proposals for the amendment or revision of this Supplementary Act.
2. Any proposal not originating from the ECOWAS Commission shall be submitted to it. The Commission shall notify Member States no later than thirty (30) days after receipt of such proposals. The Authority shall consider proposals on amendments and revisions after the three (3) month notice period given to Member States.
3. Amendments and revisions shall be adopted by the Authority and shall enter into force upon their publication in the Official Journal of the Community.

Article 23 Publication

This Supplementary Act shall be published by the ECOWAS Commission in the Official Journal of the Community within thirty (30) days of its signing by the Heads of State and Government. It shall also be published by each Member State in its National Gazette within thirty (30) days of notification by the Commission.

Article 24 Entry into force

This Supplementary Act shall enter into force upon its publication. Consequently, Member States shall undertake to commence implementation of its provisions upon its entry into force.

Article 25 Miscellaneous Provisions

The Supplementary Act shall supersede any other contrary provisions.

Article 26 Depository Authority

This Supplementary Act shall be deposited at the Commission which shall forward certified copies to all Member States and shall register same with the African Union, United Nations Organisation and all other organisations selected by the Council.

IN FAITH WHEREOF, WE, THE HEADS OF STATE AND
GOVERNMENT OF THE MEMBER STATES OF THE ECONOMIC
COMMUNITY OF WEST AFRICAN STATES (ECOWAS), HAVE
SIGNED THIS SUPPLEMENTARY ACT

DONE AT ABUJA, THIS 19TH DAY OF AUGUST 2011

IN SINGLE ORIGINAL IN ENGLISH, FRENCH AND PORTUGUESE
LANGUAGES, ALL TEXTS BEING
EQUALLY AUTHENTIC



SIXTY-SIXTH ORDINARY SESSION OF THE COUNCIL OF MINISTERS

Abuja, 17 - 19 August 2011

RECOMMENDATION C/REC.4/08/11 ON THE ABOLITION OF RESIDENCE PERMITS FOR COMMUNITY CITIZENS WITHIN THE ECOWAS REGION

THE COUNCIL OF MINISTERS,

MINDFUL of Articles 10, 11 and 12 of the ECOWAS Treaty as amended, establishing the Council of Ministers and defining its functions and composition;

MINDFUL of Articles 3 and 4 of the ECOWAS Treaty signed on 24 July 1993 respectively stating the aims and objectives of the Community, as well as the fundamental principles of the Community;

MINDFUL of Protocol *AIP1/5/79* on the free movement of persons and goods, right of residence and establishment and its subsequent Protocols;

MINDFUL of Protocol *AIP.4/5/82* of the Authority of Heads of State and Government on interstate road transit of goods;

CONSIDERING the Final Communiqué of the Mini Summit of ECOWAS Heads of State and Government on the establishment of an ECOWAS area without borders, which called for the abolition of the residence permit requirement for all Community citizens, in the desire to guarantee equal treatment for them in the Member States;

CONSIDERING that notwithstanding the efforts deployed within the sub-region, Community citizens encounter impediments to movement, stay and establishment in Community countries;

CONSIDERING that, by virtue of the provisions of Protocol A/P1/5/79 on the free movement of persons and goods, right of residence and establishment, ECOWAS citizens are entitled to enter, carry out business, and establish in the Member States;

CONSIDERING that the right of entry, residence and establishment should gradually become effective through the removal of all obstacles to the free movement of persons and goods and the right of residence and establishment;

CONVINCED that this is the opportune moment to abolish the residence permit requirement for Community citizens who move within, or are established in, ECOWAS Member States;

CONSIDERING the urgent need to speed up sub-regional integration and boost the effectiveness of a common area with a view to ensuring freedom of movement, residence and establishment of Community citizens in all ECOWAS Member States;

AWARE of the difficulties Community citizens encounter when they travel within, or become established in, a country other than their countries of origin;

CONVINCED that only the abolition of the residence permit will ensure total freedom of movement, residence and establishment for Community citizens, and put an end to the many and diverse impediments to intra-Community trade;

DESIROUS, therefore, of ensuring the Member States' total abolition of the residence permit requirement for Community citizens in all ECOWAS Member States;

HEREBY RECOMMENDS that the Authority of Heads of State and government adopt the Supplementary Act annexed to this document, on the abolition of Residence Permits for Community Citizens within the ECOWAS Region.

DONE AT ABUJA, THIS 19TH DAY OF AUGUST 2011



.....
H.E. OLUGBENGA ASHIRU

CHAIRMAN

FOR COUNCIL

FORTIETH ORDINARY SESSION OF THE AUTHORITY OF
HEADS OF STATE AND GOVERNMENT

Abuja, ... 2011

SUPPLEMENTARY ACT AISP...../08/11 ON THE ABOLITION OF
RESIDENCE PERMITS FOR COMMUNITY CITIZENS WITHIN THE
ECOWAS REGION

THE HIGH CONTRACTING PARTIES,

MINDFUL of Articles 7, 8 and 9 of the Revised ECOWAS Treaty establishing the Authority of Heads of State and Government and laying down its membership and functions;

MINDFUL of Articles 3 and 4 of the ECOWAS Treaty signed on 24 July 1993 respectively stating the aims and objectives of the Community, as well as the fundamental principles of the Community;

MINDFUL of Protocol AIP1/5/79 on the free movement of persons and goods, right of residence and establishment and its subsequent Protocols;

MINDFUL of Protocol AIP.4/5/82 of the Authority of Heads of State and Government on interstate road transit of goods;

CONSIDERING the Final Communiqué of the Mini Summit of ECOWAS Heads of State and Government on the establishment of an ECOWAS area without borders, which called for the abolition of the residence permit requirement for all Community citizens, in the desire to guarantee equal treatment for them in the Member States;

CONSIDERING that notwithstanding the efforts deployed within the sub-region, Community citizens encounter impediments to movement, stay and establishment in Community countries;

CONSIDERING that, by virtue of the provisions of Protocol *AIP1/5/79* on the free movement of persons and goods, right of residence and establishment, ECOWAS citizens are entitled to enter, carry out business, and establish in the Member States;

CONSIDERING that the right of entry, residence and establishment should gradually become effective through the removal of all obstacles to the free movement of persons and goods and the right of residence and establishment;

CONVINCED that this is the opportune moment to abolish the residence permit requirement for Community citizens who move within, or are established in, ECOWAS Member States;

CONSIDERING the urgent need to speed up sub-regional integration and boost the effectiveness of a common area with a view to ensuring freedom of movement, residence and establishment of Community citizens in all ECOWAS Member States;

AWARE of the difficulties Community citizens encounter when they travel within, or become established in, a country other than their countries of origin;

CONVINCED that only the abolition of the residence permit will ensure total freedom of movement, residence and establishment for Community citizens, and put an end to the many and diverse impediments to intra-Community trade;

DESIROUS, therefore, of ensuring the Member States' total abolition of the residence permit requirement for Community citizens in all ECOWAS Member States;

ON PROPOSAL by the 7th Forum of ECOWAS Ministers in charge of security issues in ECOWAS Member States held in Abuja, Nigeria on 6 November 2009;

ON RECOMMENDATION by the Sixty-fifth Session of the Council of Ministers held in Abuja from ... to ... November 2010;

HEREBY AGREE AS FOLLOWS:

ARTICLE 1: ABOLITION OF RESIDENCE PERMITS

By virtue of this Supplementary Act, the residence permit requirement is hereby abolished for all Community citizens within the ECOWAS area, with a view to ensuring equal treatment for them in the Member States.

ARTICLE 2: AMENDMENT AND REVIEW

(1) Any Member State, the Council of Ministers, ECOWAS Parliament and ECOWAS Commission may submit proposals for amendment or review of this Supplementary Act.

(2) Proposals not emanating from the ECOWAS Commission shall be submitted to it. The Commission shall communicate all the proposals to the Member States no later than thirty (30) days after receipt. The Authority shall consider the amendment and review of proposals on expiry of a (3) three-month deadline granted the Member States.

(3) The amendments and reviews shall be adopted by the Authority in keeping with the provisions of Article 9 of the Revised ECOWAS Treaty, and shall enter into force upon publication in the Official Journal of the Community.

ARTICLE 3: PUBLICATION

This Supplementary Act shall be published by the Commission in the Official Journal of the Community within thirty (30) days of signature by the Chairman of the Conference of Heads of State and Government. It shall also be published by each Member State in its National Gazette within thirty days of notification by the Commission.

ARTICLE 4: ENTRY INTO FORCE

1. This Supplementary Act shall enter into force upon its publication. The Member States therefore undertake to commence the implementation of its provisions once it enters into force.

2. This Supplementary Act shall be appended to the ECOWAS Treaty of which it shall form an integral part.

Article 5: DEPOSITORY AUTHORITY

This Supplementary Act shall be deposited at the Commission, which shall forward certified true copies thereof to all Member States and register same with the African Union, the United Nations Organisation and all other organisations, as Council may determine.

IN WITNESS WHEREOF WE, THE HEADS OF STATE AND
GOVERNMENT OF THE ECONOMIC COMMUNITY OF WEST
AFRICAN STATES, HAVE SIGNED THIS SUPPLEMENTARY ACT

DONE AT ABUJA THIS ... DAY OF DECEMBER 2011

IN A SINGLE ORIGINAL IN THE FRENCH, ENGLISH AND
PORTUGUESE LANGUAGES, ALL THREE (3) TEXTS BEING
EQUALLY AUTHENTIC



SIXTY-SIXTH ORDINARY SESSION OF THE COUNCIL OF MINISTERS

Abuja, August 2011

RECOMMENDATION C/REC.5/08/11 ADOPTING A (SCHENGEN- TYPE) SINGLE VISA SYSTEM WITHIN THE ECOWAS REGION

THE COUNCIL OF MINISTERS,

MINDFUL of Articles 10, 11 and 12 of the ECOWAS Treaty as amended, establishing the Council of Ministers and defining its functions and composition;

MINDFUL of Articles 3 and 4 of the ECOWAS Treaty adopted on 24 July 1993, which state respectively the aims and objectives of the Community as well as its fundamental principles;

MINDFUL of Protocol AIP1/5/79 on the free movement of persons and goods, right of residence and establishment and its subsequent Protocols;

MINDFUL of Protocol AIP.4/5/82 of the Authority of Heads of State and Government on the road transit of goods between Member States;

CONSIDERING the Final Communique of the mini Summit of ECOWAS Heads of State and Government on the establishment of a borderless ECOWAS region that requires the adoption of a Single Visa System (Shengen- type) for any visitor who wishes to enter any Member State;

CONSIDERING that the approach is aimed at facilitating ECOWAS Member States' access to foreign visitors and investors and promoting tourism within the Community region;

CONSIDERING that, in the framework of the regional integration process, establishment of the single visa system is one of the important stages for free movement of persons and goods;

CONVINCED that it is now opportune to establish a multi-country (Shengen type) single visa system that may enable any visitor to a Community Member State to travel with a single visa to any State of his/her choice without requiring any other special administrative formality;

CONSIDERING the urgent need to accelerate regional integration and the effectiveness of a Community area with a view to ensuring free movement, promotion of foreign investment, and tourism;

AWARE of the difficulties encountered by foreign visitors, tourists and investors when they plan to travel within the Community area;

CONVINCED that adoption of single Community visa system is one of the indispensable factors for the promotion of foreign investments and tourism;

DESIROUS, therefore, of ensuring that the Member States allow any foreign visitor issued with a visa by one Member State is able to move within the other Member States without any special formality;

HEREBY RECOMMENDS that the Authority of Heads of State and government adopt the Supplementary Act annexed to this document adopting a (Schengen-type) single visa system within the ECOWAS Region.

DONE AT ABUJA, THIS 19TH DAY OF AUGUST 2011

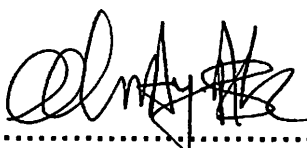

.....
H.E. OLUGBENGA ASHIRU

CHAIRMAN

FOR COUNCIL

**FORTIETH ORDINARY SESSION OF THE AUTHORITY OF
HEADS OF STATE AND GOVERNMENT**

Abuja, ... 2011

**SUPPLEMENTARY ACT A1SP.../08/11 ADOPTING A (SCHENGEN-
TYPE) SINGLE VISA SYSTEM WITHIN THE ECOWAS REGION**

THE HIGH CONTRACTING PARTIES,

MINDFUL of Articles 7, 8 and 9 of the Revised ECOWAS Treaty establishing the Authority of Heads of State and Government and laying down its membership and functions; d

MINDFUL of Articles 3 and 4 of the ECOWAS Treaty adopted on 24 July 1993, which state respectively the aims and objectives of the Community as well as its fundamental principles;

MINDFUL of Protocol A1P1/5/79 on the free movement of persons and goods, right of residence and establishment and its subsequent Protocols;

MINDFUL of Protocol A1P.4/5/82 of the Authority of Heads of State and Government on the road transit of goods between Member States;

CONSIDERING the Final Communiqué of the mini Summit of ECOWAS Heads of State and Government on the establishment of a borderless ECOWAS region that requires the adoption of a Single Visa System (Shengen- type) for any visitor who wishes to enter any Member State;

CONSIDERING that the approach is aimed at facilitating ECOWAS Member States' access to foreign visitors and investors and promoting tourism within the Community region;

CONSIDERING that, in the framework of the regional integration process, establishment of the single visa system is one of the important stages for free movement of persons and goods;

CONVINCED that it is now opportune to establish a multi-country (Shengen type) single visa system that may enable any visitor to a Community Member State to travel with a single visa to any State of his/her choice without requiring any other special administrative formality;

CONSIDERING the urgent need to accelerate regional integration and the effectiveness of a Community area with a view to ensuring free movement, promotion of foreign investment, and tourism;

AWARE of the difficulties encountered by foreign visitors, tourists and investors when they plan to travel within the Community area;

CONVINCED that adoption of single Community visa system is one of the indispensable factors for the promotion of foreign investments and tourism;

DESIROUS, therefore, of ensuring that the Member States allow any foreign visitor issued with a visa by one Member State is able to move within the other Member States without any special formality;

ON PROPOSAL by the 7th Forum of Ministers in charge of security questions in the ECOWAS Member States held in Abuja (Nigeria) on 6th November 2009;

ON RECOMMENDATION by the Sixty-Sixth Session of the ECOWAS Council of Ministers held in Abuja from ... to ... November 2010;

HEREBY AGREE AS FOLLOWS:

ARTICLE 1: ADOPTION OF A SINGLE VISA SYSTEM

It is hereby adopted by this Supplementary Act, the multi-country (Schengen type) Single Visa system for all foreign visitors to the ECOWAS region.

ARTICLE 2: IMPLEMENTATION

Member States undertake to ensure effective implementation of this Supplementary Act upon its publication.

ARTICLE 3: AMENDMENT AND REVISION

(1) Any Member State, the Council of Ministers, ECOWAS Parliament or the ECOWAS Commission may submit proposals for the amendment or revision of this Supplementary Act.

(2) Proposals initiated by any institution other than the ECOWAS Commission shall be submitted to the ECOWAS Commission, which shall transmit such proposals to all Member States no later than thirty (30) days after receiving such proposals. The Authority shall consider the proposed amendments or revisions on expiry of the three-month deadline granted to Member States.

(3) Amendments or revisions shall be adopted by the Authority in conformity with Article 9 of the Revised ECOWAS Treaty. They shall come into force upon their publication in the Official Journal of the Community.

ARTICLE 4: PUBLICATION

This Supplementary Act shall be published by the Commission in the Official Journal of the Community within thirty (30) days after signature by the Chairman of the Authority of Heads of State and Government. It

shall also be published by each Member State in its Official Gazette within thirty (30) days after notification by the Commission thereof.

ARTICLE 5: ENTRY INTO FORCE

1. This Supplementary Act shall enter into force upon its publication. Consequently, all Member States undertake to start implementing its provisions upon its entry into force.
2. This Supplementary Act shall constitute an annex to the ECOWAS Treaty, of which it shall form an integral part.

Article 6: DEPOSITORY AUTHORITY

This Supplementary Act shall be deposited with the Commission which shall transmit certified true copies to all Member States and register with the African Union, the United Nations Organisation, and such other organisations as Council may determine.

IN WITNESS WHEREOF WE, THE HEADS OF STATE AND
GOVERNMENT OF THE ECONOMIC COMMUNITY OF WEST
AFRICAN STATES, HAVE SIGNED THIS SUPPLEMENTARY ACT

DONE AT ABUJA, THIS DAY OF 2011

IN A SINGLE ORIGINAL IN THE ENGLISH, FRENCH AND
PORTUGUESE LANGUAGES, ALL THREE (3) TEXTS EQUALLY
BEING AUTHENTIC



SIXTY-SIXTH ORDINARY SESSION OF THE COUNCIL OF MINISTERS

Abuja, 17 - 19th August 2011

RECOMMENDATION C/REC.6/08/11 SUPPORTING THE CANDIDATURE OF DR. RENE KOUASSI FOR ELECTION TO THE POST OF COMMISSIONER FOR ECONOMIC AFFAIRS OF THE AFRICAN UNION COMMISSION

THE COUNCIL OF MINISTERS,

MINDFUL of Articles 10, 11 and 12 of the ECOWAS Treaty as amended, establishing the Council of Ministers and defining its functions and composition;

MINDFUL of Decision A1DEC.2/07/10 of 2nd July 2010 adopting the Rules of Procedure of the Authority of Heads of State and Government;

MINDFUL of Article 13 paragraph 3 of the Rules of Procedure of the Authority of Heads of State and Government which provides that, in between two sessions, the Chairman of the Authority shall exercise the powers of the Authority and take decisions on its behalf;

RECALLING that, at the 39th Ordinary Session of the Authority held in Abuja on 23 and 24 March 2011, the mandate of the Federal Republic of Nigeria as Chair was renewed by the Heads of State and Government until 31st December 2011;

CONSIDERING that the Republic of Côte d'Ivoire has sought the other Member States' support for the candidature of its national, Or Rene Kouassi, for election as--- Commissioner for Economic Affairs in the African Union Commission;

CONSIDERING that Or. Rene Kouassi has the requisite qualifications, experience and skills to acquit himself creditably of the responsibilities that may be assigned him within the African Union Commission;

NOTING that the ECOWAS Commission has been informed only of the candidature of Or Rene Kouassi for the above-mentioned election and that the Republic of Côte d'Ivoire is the only Member State seeking the support of the other Member States for its candidate.

DETERMINED to support the candidatures of the most deserving Community citizens for recruitment into international organisations which are considered of utmost interest to the West African region;

DESIROUS of adopting a common position in support of the candidature of Dr Rene Kouassi and ensuring his actual appointment to the African Union Commission;

HEREBY RECOMMENDS that the Authority of Heads of State and government adopt the Decision annexed to this document, on supporting the candidature of Or. Rene KOUASSI for election to the post of Commissioner for Economic Affairs of the African Union Commission.

DONE AT ABUJA, THIS 19TH DAY OF AUGUST 2011

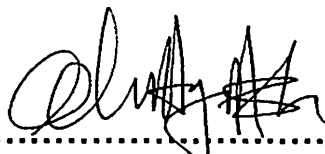

.....
H.E. OLUGBE GA ASHIRU

CHAIRMAN

FOR COUNCIL



**DECISION CIAHSG.3108/11 SUPPORTING THE CANDIDATURE
OF DR. RENE KOUASSI FOR ELECTION TO THE POST OF
COMMISSIONER FOR ECONOMIC AFFAIRS OF THE AFRICAN
UNION COMMISSION**

**THE CHAIRMAN OF THE AUTHORITY OF HEADS OF STATE
AND GOVERNMENT**

MINDFUL of Articles 7, 8 and 9 of the ECOWAS Treaty as amended, establishing the Authority of Heads of State and Government and defining its composition and functions;

MINDFUL of Decision AIDEC.2/07/10 of 2nd July 2010 adopting the Rules of Procedure of the Authority of Heads of State and Government;

MINDFUL of Article 13 paragraph 3 of the Rules of Procedure of the Authority of Heads of State and Government which provides that, in between two sessions, the Chairman of the Authority shall exercise the powers of the Authority and take decisions on its behalf;

RECALLING that, at the 39th Ordinary Session of the Authority held in Abuja on 23 and 24 March 2011, the mandate of the Federal Republic of Nigeria as Chair was renewed by the Heads of State and Government until 31st December 2011;

CONSIDERING that the Republic of Cote d'Ivoire has sought the other Member States' support for the candidature of its national, Or Rene Kouassi, for election as--- Commissioner for Economic Affairs in the African Union Commission;

CONSIDERING that Or. Rene Kouassi has the requisite qualifications, experience and skills to acquit himself creditably of the responsibilities that may be assigned him within the African Union Commission;



- 2 -

NOTING that the ECOWAS Commission has been informed only of the candidature of Or Rene Kouassi for the above-mentioned election and that the Republic of Côte d'Ivoire is the only Member State seeking the support of the other Member States for its candidate.

DETERMINED to support the candidatures of the most deserving Community citizens for recruitment into international organisations which are considered of utmost interest to the West African region;

DESIROUS of adopting a common position in support of the candidature of Or René Kouassi and ensuring his actual appointment to the African Union Commission;

ON THE RECOMMENDATION by the Sixty-sixth Session of the Council of Ministers held in Abuja from 17 to 19 August 2011;

HEREBY DECIDES AS FOLLOWS

ARTICLE 1

1. ECOWAS Member States hereby support the candidacy of Dr. Rene Kouassi for election into the position of Commissioner for Economic Affairs in the African Union Commission.
2. The competent authorities of the Member States shall take appropriate measures to ensure that they vote for Or Rene KOASSIE at the election referred to in paragraph 1 of this Article.

ARTICLE 2

The competent authorities of the Member States and the President of the ECOWAS Commission shall appeal to the other sub-regions to undertake measures to ensure the attainment of the purpose of this Decision.



- 3 -

ARTICLE 3

This Decision shall be published by the President of the Commission . in the Official Journal of the Community within thirty (30) days of its signature by the Chairman of the Authority. It shall also be published by each Member State in its National Gazette within thirty (30) days after due notification by the Commission.

DONE AT ABUJA, THIS 22ND DAY OF AUGUST 2011

H.E. GOODLUCK EBELE JONATHAN (GCFR)

CHAIRMAN

FOR THE AUTHORITY



SIXTY-SIXTH ORDINARY SESSION OF THE COUNCIL
OF MINISTERS

Abuja, August 2011

RECOMMENDATION C/REC.7/08/11 SUPPORTING THE
CANDIDATURE OF PROFESSOR JEAN-PIERRE EZIN FOR
ELECTION AS COMMISSIONER FOR HUMAN RESOURCES,
SCIENCE AND TECHNOLOGY OF THE AFRICAN UNION
COMMISSION

THE COUNCIL OF MINISTERS,

MINDFUL of Articles 10, 11 and 12 of the ECOWAS Treaty as amended, establishing the Council of Ministers and defining its functions and composition;

MINDFUL OF Decision AIOEC.2/07/10 of 2 July 2010 adopting the Rules of Procedure of the Authority of Heads of State and Government;

MINDFUL of Article 13 paragraph 3 of the Rules of Procedure of the Authority of Heads of State and Government prescribing in Article 13 Paragraph 3 that, in-between two sessions, the Chairman shall exercise the powers of the Authority and act on its behalf;

RECALLING that at the Thirty-Ninth Ordinary Session of Authority held in Abuja on 23 and 24 March 2011, the Heads of State and Government renewed the tenure of the Federal Republic of Nigeria as Chair of the ECOWAS Authority of Heads of State and Government until 31 December 2011;

CONSIDERING that the Republic of Benin is seeking the support of the other Member States for the candidature of a Beninois national, Prof. Jean-Pierre EZIN, for election as Commissioner for Human Resources, Science and Technology of the African Union Commission;

CONSIDERING that Prof. Jean-Pierre EZIN possesses the requisite qualifications, experience and skills to enable him acquit himself creditably of the responsibilities that may be assigned him as Commissioner for Human Resources, Science and Technology of the African Union Commission;

NOTING that the ECOWAS Commission has been apprised only of the candidature of Professor EZIN for the election referred to above, and that the Republic of Benin is the only Member State seeking the other Member States' support for its candidate;

DETERMINED to support the candidatures of the most deserving ECOWAS citizens for recruitment into International Organisations of essential interest to the West African region;

DESIROUS of adopting a common position for the candidature of Professor Jean-Pierre EZIN and ensuring that he is actually elected Commissioner for Human Resources, Science and Technology of the African Union Commission

HEREBY RECOMMENDS that the Authority of Heads of State and government adopt the Decision annexed to this document, supporting the candidature of Professor JEAN-PIEERE EZIN for election as Commissioner for Human Resources, Science and Technology of the African Union.

DONE AT ABUJA, THIS 19TH DAY OF AUGUST 2011

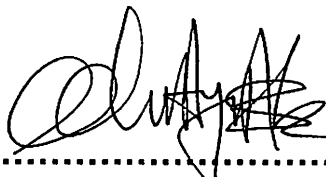

.....
H.E. OLUGBEN A ASHIRU

CHAIRMAN

FOR COUNCIL



**DECISION C/AHSG.4/08/11 ON SUPPORT FOR THE
CANDIDATURE OF PROFESSOR JEAN-PIERRE EZIN FOR
ELECTION AS COMMISSIONER FOR HUMAN RESOURCES,
SCIENCE AND TECHNOLOGY OF THE AFRICAN UNION
COMMISSION**

**THE CHAIRMAN OF THE AUTHORITY OF HEADS OF STATE
AND GOVERNMENT,**

MINDFUL OF Articles 7, 8 and 9 of the ECOWAS Treaty as amended establishing the Authority of Heads of State and Government and defining its composition and functions;

MINDFUL OF Decision AIDEC.2/07/10 of 2 July 2010 adopting the Rules of Procedure of the Authority of Heads of State and Government;

MINDFUL of Article 13 paragraph 3 of the Rules of Procedure of the Authority of Heads of State and Government prescribing in Article 13 Paragraph 3 that, in-between two sessions, the Chairman shall exercise the powers of the Authority and act on its behalf;

RECALLING that at the Thirty-Ninth Ordinary Session of Authority held in Abuja on 23 and 24 March 2011, the Heads of State and Government renewed the tenure of the Federal Republic of Nigeria as Chair of the ECOWAS Authority of Heads of State and Government until 31 December 2011;

CONSIDERING that the Republic of Benin is seeking the support of the other Member States for the candidature of a Beninois national, Prof. Jean-Pierre EZIN, for election as Commissioner for Human Resources, Science and Technology of the African Union Commission;

CONSIDERING that Prof. Jean-Pierre EZIN possesses the requisite qualifications, experience and skills to enable him acquit himself creditably of the responsibilities that may be assigned him as Commissioner for Human Resources, Science and Technology of the African Union Commission;



-2-

NOTING that the ECOWAS Commission has been apprised only of the candidature of Professor EZIN for the election referred to above, and that the Republic of Benin is the only Member State seeking the other Member States' support for its candidate;

DETERMINED to support the candidatures of the most deserving ECOWAS citizens for recruitment into International Organisations of essential interest to the West African region;

DESIROUS of adopting a common position for the candidature of Professor Jean-Pierre EZIN and ensuring that he is actually elected Commissioner for Human Resources, Science and Technology of the African Union Commission

ON THE RECOMMENDATION of the Sixty-Sixth Ordinary Session of the Council of Ministers held in Abuja from 17 to 19 August 2011;

HEREBY DECIDES

ARTICLE 1

1. ECOWAS Member States hereby support the candidature of Professor Jean-Pierre EZIN for election as Commissioner for Human Resources, Science and Technology of the African Union Commission.
2. The competent authorities of the Member States shall take the appropriate measures to ensure that they vote for Professor Jean-Pierre EZIN at the election referred to in paragraph 1 of this Article.



-3-

ARTICLE 2

The Competent Authorities of the ECOWAS Member States and the President of the ECOWAS Commission shall appeal to states in other sub- regions to ensure the attainment of the purpose of this Decision.

ARTICLE 3

This Decision shall be published by the ECOWAS Commission in the Official Journal of the Community within thirty (30) days of its signature by the Chairman. It shall also be published by each Member State in its Official Gazette within the (30) thirty-day timeframe after notifying the Commission thereof.

DONE AT ABUJA, THIS 22ND DAY OF AUGUST 2011

H.E. GOODLUCK EBELE JONATHAN (GCFR)

FOR THE AUTHORITY,

THE CHAIRMAN



**SIXTY-SIXTH ORDINARY SESSION OF THE COUNCIL
OF MINISTERS**

Abuja, August 2011

**RECOMMENDATION C/REC.8/08/11 ON SUPPORT FOR THE
CANDIDATURE OF MRS FATOU BOMM BENSOU DA FOR
ELECTION AS PROSECUTOR AT THE INTERNATIONAL
CRIMINAL COURT (ICC)**

THE COUNCIL OF MINISTERS,

MINDFUL of Articles 10, 11 and 12 of the ECOWAS Treaty as amended, establishing the Council of Ministers and defining its functions and composition;

MINDFUL OF Decision A1DEC.2/07/10 of 2 July 2010 adopting the Rules of Procedure of the Authority of Heads of State and Government;

MINDFUL of Article 13 paragraph 3 of the Rules of Procedure of the Authority of Heads of State and Government, which provides in Article 13 Paragraph 3 that in-between two sessions, the Chairman shall exercise the powers of the Authority and act on its behalf;

RECALLING that at the Thirty-Ninth Ordinary Session of Authority held in Abuja from 23 to 24 March 2011, the Authority of Heads of State and-Government renewed the tenure- of the Federal Republic of Nigeria as Chair of the ECOWAS Authority of Heads of State and Government until 31 December 2011 ;

CONSIDERING that the Republic of The Gambia is seeking the other Member States' support for the candidature of a Gambian national, Mrs. Fatou Bomm BENSOU DA for election as Prosecutor at the International Criminal Court;

CONSIDERING that Mrs. Fatou BENSOU DA possesses the requisite qualifications, experience and skills to enable her acquit herself creditably of the responsibilities that may be assigned her as Prosecutor of the International Criminal Court;

NOTING that the ECOWAS Commission has been informed only of the candidature of Mrs. Fatou BENSOU DA for the election referred to above, and that the Republic of The Gambia is the only Member State seeking the other Member States' support for its candidate;

DETERMINED to support candidatures of the most deserving ECOWAS citizens for recruitment into International Organisations which are considered of utmost interest to the West African region;

DESIROUS of adopting a common position for the candidature of Mrs. Fatou Bomm BENSOU DA and ensuring that she is actually elected Prosecutor of the International Criminal Court;

DESIROUS of adopting a common position for the candidature of Mrs. Fatou Bomm BENSOU DA and ensuring that she is actually elected Prosecutor of the International Criminal Court;

HEREBY RECOMMENDS that the Authority of Heads of State and government adopt the Decision annexed to this document, supporting the candidature of Mrs. Fatou Bomm BENSOU DA for election as Prosecutor at the International Criminal Court (ICC).

DONE AT ABUJA, THIS 19TH DAY OF AUGUST 2011

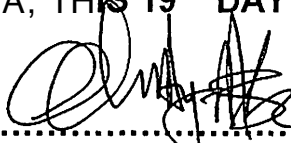

.....
H.E. OLUGBENGA ASHIRU

CHAIRMAN

FOR COUNCIL



DECISION C/AHSG.5/08/11 ON SUPPORT FOR THE
CANDIDATURE OF MRS FATOU BOMM BENSOU DA FOR
ELECTION AS PROSECUTOR AT THE INTERNATIONAL
CRIMINAL COURT (ICC)

THE CHAIRMAN OF THE AUTHORITY OF HEADS OF STATE
AND GOVERNMENT,

MINDFUL OF Articles 7, 8 and 9 of the ECOWAS Treaty as amended establishing the Authority of Heads of State and Government and defining its composition and functions;

MINDFUL OF Decision A1DEC.2/07/10 of 2 July 2010 adopting the Rules of Procedure of the Authority of Heads of State and Government;

MINDFUL of Article 13 paragraph 3 of the Rules of Procedure of the Authority of Heads of State and Government, which provides in Article 13 Paragraph 3 that in-between two sessions, the Chairman shall exercise the powers of the Authority and act on its behalf;

RECALLING that at the Thirty-Ninth Ordinary Session of Authority held in Abuja from 23 to 24 March 2011, the Authority of Heads of State and Government renewed the tenure of the Federal Republic of Nigeria as Chair of the ECOWAS Authority of Heads of State and Government until 31 December 2011;

CONSIDERING that the Republic of The Gambia is seeking the other Member States' support for the candidature of a Gambian national, Mrs. Fatou Bomm BENSOU DA for election as Prosecutor at the International Criminal Court;

CONSIDERING that Mrs. Fatou BENSOU DA possesses the requisite qualifications, experience and skills to enable her acquit herself creditably of the responsibilities that may be assigned her as Prosecutor of the International Criminal Court;



-2-

NOTING that the ECOWAS Commission has been informed only of the candidature of Mrs. Fatou BENSOU DA for the election referred to above. and that the Republic of The Gambia is the only Member State seeking the other Member States' support for its candidate;

DETERMINED to support candidatures of the most deserving ECOWAS citizens for recruitment into International Organisations which are considered of utmost interest to the West African region;

DESIROUS of adopting a common position for the candidature of Mrs. Fatou Bomm BENSOU DA and ensuring that she is actually elected Prosecutor of the International Criminal Court;

UPON RECOMMENDATION by the Sixty-Sixth Ordinary Session of the Council of Ministers held in Abuja from 17 to 18 August 2011;

HEREBY DECIDES

ARTICLE 1

1. ECOWAS Member States hereby support the candidature of Mrs. Fatou Bomm BENSOU DA for election as Prosecutor at the International Criminal Court.
2. The competent authorities of the Member States shall take the appropriate measures to ensure that they vote for Mrs. Fatou BENSOU DA at the election referred to in paragraph 1 of this Article.

ARTICLE 2

The competent authorities of the ECOWAS Member States and the President of the ECOWAS Commission shall appeal to the other sub-regions to ensure the attainment of the purpose of this Decision.



-3-

ARTICLE 3

This Decision shall be published by the ECOWAS Commission in the Official Journal of the Community within thirty (30) days of its signature by the Chairman of the Authority. It shall also be published by each Member State in its Official Gazette within the 30) thirty-day timeframe after notifying the Commission thereof.

DONE AT ABUJA, THIS 22ND DAY OF AUGUST 2011

H.E. GOODLUCK EBELE JONATHAN (GCFR)

FOR THE AUTHORITY.

THE CHAIRMAN



**SIXTY-SIXTH ORDINARY SESSION
OF THE COUNCIL OF MINISTERS**

Abuja, 17 - 19 August 2011

**RECOMMENDATION C/REC.9/08/11 SUPPORTING THE
CANDIDATURE OF THE TOGOLESE REPUBLIC FOR THE
POST OF NON-PERMANENT MEMBER IN THE UNITED
NATIONS SECURITY COUNCIL**

THE COUNCIL OF MINISTERS,

MINDFUL of Articles 10, 11 and 12 of the ECOWAS Treaty as amended, establishing the Council of Ministers and defining its functions and composition;

MINDFUL of Decision AIDEC.2/07/10 of 2nd July 2010 adopting the Rules of Procedure of the Authority of Heads of State and Government;

MINDFUL of Article 13 paragraph 3 of the Rules of Procedure of the Authority of Heads of State and Government which provides that, in between two sessions, the Chairman of the Authority shall perform the duties of the Authority and take decisions on its behalf;

RECALLING that at its 39th Ordinary Session held in Abuja on 23 and 24 March 2011, the Heads of State and Government renewed the mandate of the Federal Republic of Nigeria as Chairman of the Authority of Heads of State and Government until 31st December 2011 ;

CONSIDERING that the Togolese Republic has sought the support of other Member States for its election as non-permanent member of the United Nations Security Council;

NOTING that the ECOWAS Commission has been informed only of the candidature of the Togolese Republic for the above-mentioned position and that the Togolese Republic is the only Member State seeking the other Member States' support of for its candidature;

DETERMINED to support the candidatures of Member States of the Community for positions in international organisations which are considered of utmost interest to the West African region;

DESIROUS of adopting a common position on support to the candidature of the Togolese Republic and ensuring her election as non-permanent Member of the United Nations Security Council;

ON THE RECOMMENDATION of the Sixty-sixth Session of the Council of Ministers held in Abuja from 17 to 19 August 2011

HEREBY RECOMMENDS that the Authority of Heads of State and government adopt the Decision annexed to this document, supporting the candidature of the Togolese Republic for the post of Non-Permanent Member in the United Nations Security Council

DONE AT ABUJA, THIS 19TH DAY OF AUGUST 2011

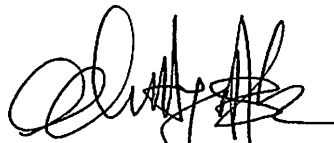

.....
H.E. OLUGBENGA ASHIRU

CHAIRMAN

FOR COUNCIL



**DECISION C/AHSG.6/08/11 SUPPORTING THE CANDIDATURE
OF THE TOGOIESE REPUBLIC FOR THE POST OF NON-
PERMANENT MEMBER IN THE UNITED NATIONS SECURITY
COUNCIL**

**THE CHAIRMAN OF THE AUTHORITY OF HEADS OF STATE
AND GOVERNMENT,**

MINDFUL of Articles 7,8 and 9 of the ECOWAS Treaty as amended establishing the Authority of Heads of State and Government and defining its composition and functions;

MINDFUL of Decision A1DEC,2/07/10 of 2nd July 2010 adopting the Rules of Procedure of the Authority of Heads of State and Government;

MINDFUL of Article 13 paragraph 3 of the Rules of Procedure of the Authority of Heads of State and Government which provides that, in "between two sessions, the Chairman of the Authority shall perform the duties of the Authority and take decisions on its behalf;

RECALLING that at its 39th Ordinary Session held in Abuja on 23 and 24 March 2011, the Heads of State and Government renewed the mandate of the Federal Republic of Nigeria as Chairman of the Authority of Heads of State and Government until 31st December 2011;

CONSIDERING that the Togolese Republic has sought the support of other Member States for its election as non-permanent member of the United Nations Security Council;

NOTING that the ECOWAS Commission has been informed only of the candidature of the Togolese Republic for the above-mentioned position and that the Togolese Republic is the only Member State seeking the other Member States' support of for its candidature;



-2-

DETERMINED to support the candidatures of Member States of the Community for positions in international organisations which are considered of utmost interest to the West African region;

DESIROUS of adopting a common position on' support to the candidature of the Togolese Republic and ensuring her election as non-permanent Member of the United Nations Security Council;

ON THE RECOMMENDATION by the Sixty-sixth Session of the Council of Ministers held in Abuja from 17 to 19 August 2011

HEREBY DECIDES

ARTICLE 1

1. ECOWAS Member States hereby support the candidature of the Togolese Republic as non-Permanent Member of the United Nations Security Council;
2. The competent authorities of the Member States shall take appropriate measures to ensure that they vote for the Togolese Republic at the election to the position referred to in paragraph 1 of this Article.

ARTICLE 2

The competent authorities of ECOWAS Member States and the President of the ECOWAS Commission shall appeal to the other sub-regions to undertake measures to ensure the attainment of the purpose of this Decision.



-3-

ARTICLE 3

This Decision shall be published by the President of the ECOWAS Commission in the Official Journal of the Community within thirty (30) days of its signature by the Chairman of the Authority. It shall also be published by each Member State in its National Gazette within thirty (30) days after notification by the Commission.

DONE AT ABUJA, THIS 22ND DAY OF AUGUST 2011

H.E. GOODLUCK EBELE JONATHAN (GCFR)

CHAIRMAN

FOR THE AUTHORITY



Sixty-Sixth Ordinary Session of the Council of Ministers

Abuja 17 - 19 August 2011

RECOMMENDATION C/REC.101 08/11 RELATING TO SUPPORT FOR THE CANDIDATURE OF MR MOHAMMED BELLO ADOKE FOR RE-ELECTION TO THE INTERNATIONAL LAW COMMISSION OF THE UNITED NATIONS

THE COUNCIL OF MINISTERS,

MINDFUL of Articles 10, 11 and 12 of the ECOWAS Treaty as amended, establishing the Council of Ministers and defining its functions and composition;

CONSIDERING that the Federal Republic of Nigeria is seeking the support of the other Member States, for the candidature of a Nigerian national, Mr Mohammed Bello ADOKE, for re-election to the United Nations International Law Commission;

CONSIDERING that Mr Mohammed Bello ADOKE possesses the requisite qualifications, experience and skills to enable him acquit himself creditably of the responsibilities that may be assigned him within the United Nations International Law Commission;

NOTING that Mr Mohammed Bello ADOKE whose candidature to the above-mentioned position has been notified to the ECOWAS Commission, and that the Federal Republic of Nigeria seeks the support of the other Member States for its candidate;

DETERMINED to support the candidatures of the most deserving ECOWAS citizens for recruitment to International Organisations which present a crucial interest to the West African region;

DESIROUS of adopting a common position on support for the candidacy of Mr Mohammed Bello ADOKE as a means of facilitating his re-election to the United Nations International Law Commission;

HEREBY RECOMMENDS that the Authority of Heads of State and government adopt the Decision annexed to this document, on support for the candidature of Mr Mohammed Bello ADOKE for re-election to the United Nations International Law Commission.

DONE AT ABUJA, THIS 19TH DAY OF AUGUST 2011

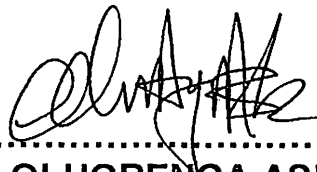

.....
H.E. OLUGBENGA ASHIRU

CHAIRMAN

FOR COUNCIL



**Fortieth Ordinary Session of the Authority of
Heads of State and Government**

Abuja, 17 - 19 August 2011

**DECISION C/AHSG.7/08/11 RELATING TO SUPPORT FOR THE
CANDIDACY OF MOHAMMED BELLO ADOKE ON HIS RE-
ELECTION TO THE UNITED NATIONS INTERNATIONAL LAW
COMMISSION**

THE AUTHORITY OF HEADS OF STATE AND GOVERNMENT,

MINDFUL of Articles 7, 8 and 9 of the ECOWAS Treaty as amended, establishing the Authority of Heads of State and Government and defining its composition and functions;

CONSIDERING that the Federal Republic of Nigeria is seeking the other Member States' support for the candidature of its national, Mr Mohammed Bello ADOKE, for re-election to the United Nations International Law Commission;

MINDFUL of the fact that Mr Mohammed Bello ADOKE has the requisite qualifications, experience and competence to acquit himself creditably of the responsibilities that may be entrusted him within the United Nations International Law Commission;

NOTING that Mr Mohammed Bello ADOKE whose candidature to the above-mentioned position has been notified to the ECOWAS Commission, and that the Federal Republic of Nigeria seeks the support of the other Member States for its candidate;

DETERMINED to support the candidatures of the most deserving Community citizens for recruitment to international organizations that have an essential bearing for the West African region;



-2-

DESIROUS of adopting a common position to support the candidacy of Mr Mohammed Bello ADOKE as a means of facilitating his effective re-election to the United Nations International Law Commission;

ON THE RECOMMENDATION of the Sixty-sixth Session of the Council of Ministers held in Abuja from 17 to 19 August 2011;

HEREBY DECIDES

ARTICLE 1

1. ECOWAS Member States hereby agree to support the candidature of Mr. Mohammed Bello ADOKE who at the forthcoming elections to the United Nations International Law Commission
2. The relevant authorities of the Member States shall take necessary measures to ensure that they vote for Mr Mohammed Bello ADOKE at the election referred to in paragraph 1 of this Article.

ARTICLE 2

The Competent Authorities of the ECOWAS Member States and the President of the ECOWAS Commission shall dialogue with States in other regions to ensure the attainment of the goal of this Decision.



- 3 -

ARTICLE 3

This Decision shall be published by the ECOWAS Commission in the Official Journal of the Community within thirty (30) days of its signature by the Chairman of the Authority of Heads of State and Government, as well as by each Member State in its Official Gazette within the stipulated timeframe after notification by the Commission thereof.

DONE AT ABUJA THIS 19TH DAY OF AUGUST 2011

THE PRESIDENT

HIS EXCELLENCY GOODLUCK EBELE JONATHAN

CHAIRMAN
FOR THE AUTHORITY